

eH-HC END-HALL HOLLOW CATHODE ION SOURCE CONTROLLER

Models: eH-HC3005-00
eH-HC30010-00

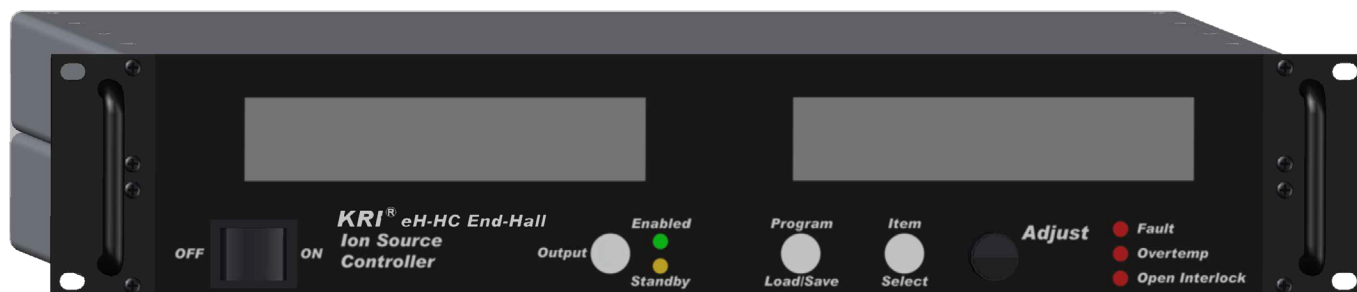

*Kaufman & Robinson, Inc.
1330 Blue Spruce Drive
Fort Collins, Colorado 80524
Tel: (970) 495-0187, Fax: (970) 484-9350
www.ionsources.com*

*Copyright © 2021 by Kaufman & Robinson, Inc.
All rights reserved. No part of this publication
may be reproduced without written permission.
October 2021, Version -
Part Number: 9007-0033*

This Page is Intentionally Blank

CONTENTS

i

Contents	
1. SAFETY.....	1-1
2. PRODUCT OVERVIEW.....	2-1
2.1 General Description.....	2-1
2.2 Theory of Operation.....	2-1
3. SPECIFICATIONS.....	3-1
3.1 Physical/Mechanical Specifications.....	3-1
3.2 Electrical Specifications.....	3-4
3.3 Cooling.....	3-4
3.4 Environmental Specifications.....	3-5
4. INSTALLATION.....	4-1
4.1 Unpacking and Inspection.....	4-1
4.2 Physical Description.....	4-1
4.3 Safety.....	4-1
4.4 Typical System Connections.....	4-2
4.5 Electrical Connections.....	4-3
4.5.1 MFC Control Connectors.....	4-4
4.5.2 Gas Valve Relay Connector.....	4-5
4.5.3 Output Connector.....	4-5
4.5.4 AC Input Connector and Earth Ground Stud.....	4-6
4.5.5 RS-232 COM PORT.....	4-7
4.5.6 DB-37 KRI® Analog Port.....	4-7
4.5.7 Interlock.....	4-7
5. LOCAL OPERATION.....	5-1
5.1 Front Panel User Interface.....	5-1
5.2 Front Panel User Interface - Basic Operation.....	5-1
5.3 DISPLAY Screens.....	5-3
5.3.1 Display - MAIN Screen.....	5-3
5.3.2 Display - SETUP ONE.....	5-3
5.3.3 Display - DISCHARGE.....	5-5
5.3.4 Display - KEEPER.....	5-5
5.3.5 Display - EMISSION.....	5-5
5.3.6 Display - STATUS.....	5-6
5.3.7 Display - SETUP TWO.....	5-6
5.4 REMOTE Parameters.....	5-7
5.4.1 NONE - Local Mode.....	5-8
5.4.2 ENABLE DB37.....	5-8
5.4.3 ALL DB37.....	5-8
5.4.4 RS-232.....	5-8
5.4.5 RS-232 ACTIVE.....	5-9
5.5 CONTROL Parameters.....	5-9
5.6 MANUAL Control.....	5-9
5.7 AUTO FIXED/LEARN Control.....	5-10
5.8 GAS ONLY Control.....	5-10

5.9 HC ONLY.....	5-11
6. REMOTE CONTROL.....	6-1
6.1 Analog Control.....	6-1
6.1.1 KRI® DB-37 Analog Interface.....	6-1
6.2 RS-232 Control.....	6-5
6.2.1 RS-232 Command Overview.....	6-5
6.2.2 RS-232 Command List.....	6-7
7. TROUBLESHOOTING.....	7-1
7.1 Basic Troubleshooting Table.....	7-1
7.2 ERROR/HELP Codes.....	7-2
8. MAINTENANCE.....	8-1
9. WARRANTY.....	9-1

Figures

Figure 2-1. A simplified schematic diagram of an eH gridless ion source and the KRI® eH-HC ion source controller.....	2-3
Figure 3-1. Outline/mounting drawings.....	3-2
Figure 3-2. Outline/mounting drawings.....	3-3
Figure 4-1. eH-HC controller system setup.....	4-2

CONTENTS

iii

Tables

Table 3-1. Mechanical Specifications.....	3-1
Table 3-2. Electrical Specifications.....	3-4
Table 3-3. Environmental Specifications.....	3-5
Table 4-1. Inventory List.....	4-1
Table 4-2. Back Panel Descriptions.....	4-3
Table 4-3. DB-15 Analog MFC Connector Pinout.....	4-4
Table 6-1. KRI® DB-37 Analog Remote Pinout.....	6-1
Table 6-2. Remote Program Select Table.....	6-4
Table 7-1. Basic Troubleshooting.....	7-1
Table 7-2. ERROR/HELP Fault Code Definitions.....	7-2



WARNING:

Danger of high-voltage personal injury.



WARNING:

Indicates death, serious injury, or property damage can result if proper precautions are not taken.



CAUTION:

Indicates some injury or property damage may result if proper precautions are not taken.



Earth Ground Terminal



Alternating Current



On (Power)



Off (Power)

1. SAFETY



WARNING:

Manual should be read before you install, operate, or maintain this product. Failure to follow instructions can lead to personal injury and/or property damage. If the equipment is used in a manner not specified by KRI, the protection provided by the equipment may be impaired. Hazardous voltages exist within the product and at the outputs. Only technically qualified personnel should install, maintain, and troubleshoot the equipment described herein. There are no user-serviceable parts inside the product.

Troubleshooting and maintenance should be carried out only after grounding the components to be worked on and assuring that power cannot be applied to those components while working on them.

This Page is Intentionally Blank

2. PRODUCT OVERVIEW

2.1 General Description

The Kaufman & Robinson, Inc (KRI®) eH-HC series of end-Hall Hollow Cathode ion source controllers are intended to be used with an end-Hall Ion Source. These controllers are available with various discharge voltage and current configurations. The eH-HC Controller contains three main power supplies (Discharge, Keeper, and Emission) along with a 4-channel gas controller and a main system controller. The Discharge Supply is a DC supply for controlling the ion beam energy and current. The Emission Supply is a DC supply for driving the cathode which supplies the emission current. The Keeper Supply is a DC supply for driving the hollow cathode.

The eH-HC Controller can be controlled manually via the front panel or remotely via the DB-37 analog port or the DB-9 RS-232 port. The controller also can store up to four programs with setpoints for all parameters.

2.2 Theory of Operation

The eH-HC end-Hall Hollow Cathode Ion Source Controller contains a Discharge power supply, Emission power supply, Keeper supply, mass flow controller (MFC), and an integrated control system to control an end-Hall Hollow Cathode Ion Source. The product has four operational modes: Auto Mode, Manual Mode, HC Only and Gas Only. Engage Auto or Manual Modes for controlling an ion source. Use Gas Only Mode as a 4 channel stand-alone gas controller. A block diagram of the eH-HC controller and connection to an end-Hall ion source is shown in Figure 2-1.

Auto Mode: Auto Mode (AUTO FIXED or AUTO LEARN) is the main operational mode of the controller and is the preferred control mode for most process operations. When in Auto Mode the user sets an initial gas flow, the Discharge voltage and current setpoints, the Emission current setpoint, and the Keeper current setpoint. When the output is enabled, the eH-HC Controller will first enable the gas channels and verify there is flow. Once there is gas flow, the controller will enable the Keeper Supply to ignite the hollow cathode plasma. Once the plasma exists, the eH-HC Controller will enable the Discharge and Emission supply. Then adjust the gas flow to modify the plasma impedance to meet the discharge voltage and current setpoints. If the source does not ignite at the set parameters, the controller will go through an advanced ignition sequence in which the Keeper voltage will be set to maximum and gas flow will be maxed to aid the plasma ignition. If the source still does not ignite, the controller will fault with a start fault. If more than one gas channel is used, the eH-HC Controller will keep the ratios of

the different gas channels the same as the initial setpoints when it changes the total gas flow to regulate the plasma impedance to maintain the discharge voltage and current setpoints.

Manual Mode: Manual Mode is intended for unique operational points, troubleshooting, and characterizing the behavior of the source/chamber. When in Manual mode the user sets the desired gas flow, the Emission current, the Discharge voltage, and either the Discharge voltage or the Discharge current setpoint, depending on which regulation mode the user needs to operate in, and sets the other parameter to maximum. For example, if the user wants to run in voltage regulation mode they would set the Discharge voltage to the desired value (say 150 V) and set the Discharge current to the maximum value. The Discharge current is then dependent upon the plasma impedance. The user must manually adjust the gas flow to obtain the desired Discharge current. If operating in current mode the gas flow would be manually adjusted to obtain the desired discharge voltage. The Emission current should always be set slightly higher than the discharge current. If emission current is too low the desired discharge current will not be achievable.

Gas Only Mode: In Gas Only Mode the eH-HC Controller can be run as purely a 4 channel gas controller. In this mode, the Discharge, Emission, and Keeper supplies are disabled. The user sets the desired gas flows for each channel, and enabling the output will enable only the gas flows for these channels.

PRODUCT OVERVIEW

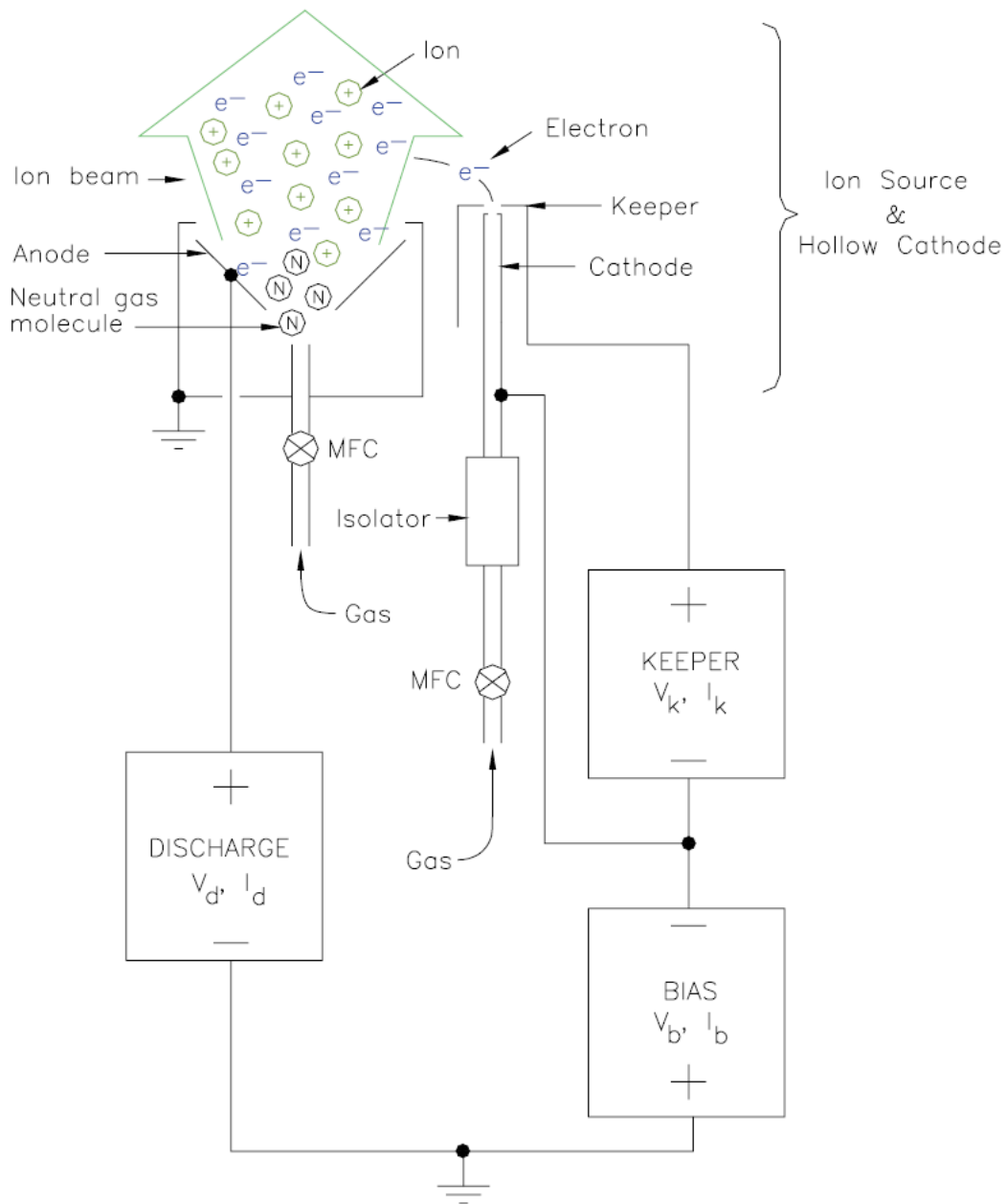

Figure 2-1. A simplified schematic diagram of an eH ion source, hollow cathode, and the KRI[®] eH-HC Ion Source Controller.

This Page is Intentionally Blank

SPECIFICATIONS

3-1

3. SPECIFICATIONS

3.1 Physical/Mechanical Specifications

Table 3-1. Mechanical Specifications

Description	Specification
Size	3.5" (H) × 19"(W) × 20"(D) 8.9 cm × 48.3 cm × 50.8 cm Note: These measurements do not include mating connectors, cables, or mounting brackets.
Weight	32.5 lb (14.7 kg)
Chassis Ground	10-32 Stud
Mounting	Rack mount 19" Note: Rear of unit must be supported

3-2

SPECIFICATIONS

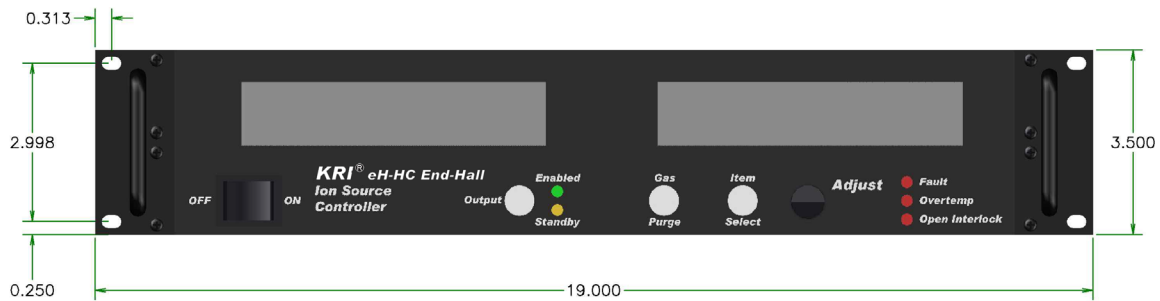

Front View

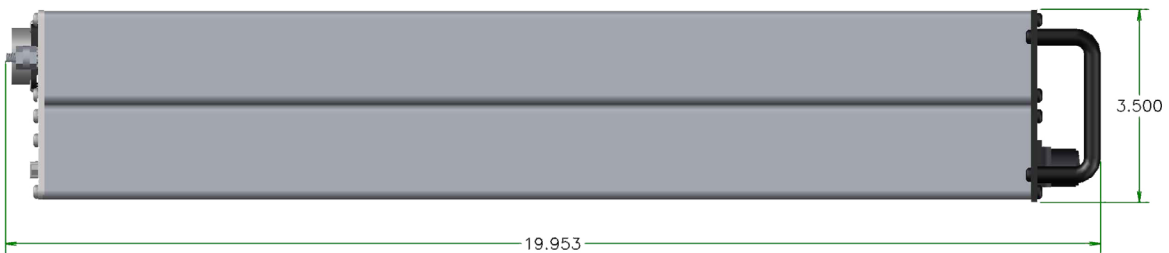

Side View

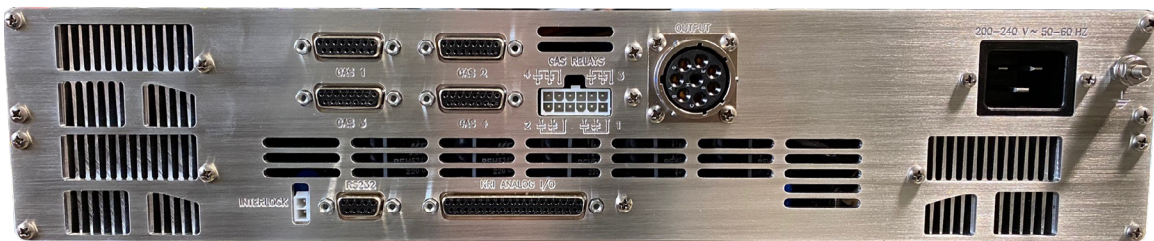

Back View

Figure 3-1. Outline/mounting drawings (units in inches).

Copyright © 2021 by Kaufman & Robinson, Inc., 1330 Blue Spruce Drive, Fort Collins, CO 80524
Tel: 970-495-0187, Internet: www.ionsources.com

SPECIFICATIONS

3-3

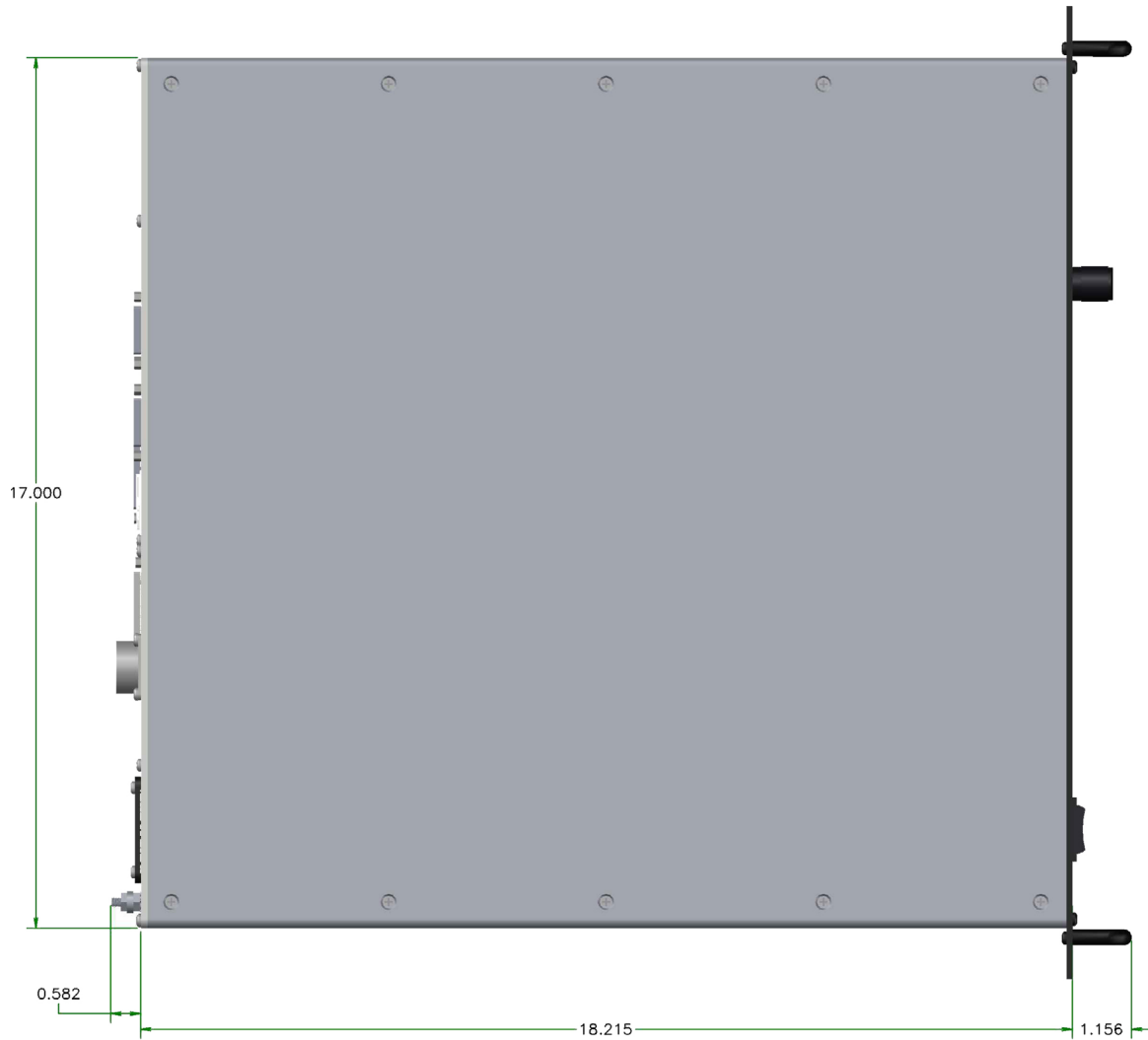

Top View

Figure 3-2. Outline/mounting drawings (units in inches).

3.2 Electrical Specifications

Table 3-2. Electrical Specifications

Description	Specification
Input Power	
Line Voltage	200-240 VAC, single phase
Line Frequency	50/60 Hz
Line Current	eH-HC3005-00 = 16 A Max eH-HC30010-00 = 16 A Max
Inrush Current	<10 A peak
Overcurrent Protection	25 A fuses
Output Power Ratings	
Total Output Power (Discharge + Hollow Cathode)	2500 W max
Discharge Output	eH-HC3005-00 = 300 V/5A eH-HC30010-00 = 300 V/10A
Keeper Output	800 V/2 A (Limited to 400 W)
Emission Current	eH-HC3005-00 = 6 A eH-HC30010-00 = 12.5 A
Output Accuracy	
Discharge Volts	0.5% of full scale +/- 0.5 V
Discharge Amps	0.5% of full scale +/- 50 mA
Keeper Volts	1% of full scale +/- 0.5 V
Keeper Amps	1% of full scale +/- 50 mA
Emission Amps	1% of full scale +/- 50 mA
General	
Boot Time	7 seconds

3.3 Cooling

The eH-HC controller is air cooled by drawing air in from the rear panel and exhausting it back out the rear panel of the unit. There must be sufficient space of at least 8 inches (20 cm) at the rear of the unit for air circulation. The rack or environment the controller is mounted in should have adequate cooling to maintain an inlet air temperature of 40°C or less.

SPECIFICATIONS

3-5

3.4 Environmental Specifications

Table 3-3. Environmental Specifications

Description	Specification
Operating Ambient Temperature	0° C to +40° C
Storage Temperature	-25° C to 55° C
Operating Humidity	5% to 85% (non condensing)
Storage Humidity	5% to 95% (non condensing)
Altitude	6500 ft (2000 m)
Pollution Degree	2
Overvoltage Category	II
Impact Rating	IK06

This Page is Intentionally Blank

4. INSTALLATION

4.1 Unpacking and Inspection

Prior to shipment the controller was tested, inspected, and deemed free of physical defects. As soon as the equipment has been unpacked, a visual inspection should be made to determine if there has been any damage during shipment. If any damage has occurred, contact both KRI® and the shipping company to report the damage (see Warranty Section). Retain packing materials in case equipment must be returned to KRI®.

4.2 Physical Description

The following items should have been supplied with the eH-HC controller.

Table 4-1. Inventory List.

Item	Description
Power cord	AC input power cord. Cords are supplied with unterminated ends.
Gas valve relay connector and pins	Mating connector and pins for the 12 pin gas valve relay connector
RS-232 cable	5' DB-9 straight through RS-232 cable
2-pin Molex Plug	2 pin Molex plug for interlock

4.3 Safety

The eH-HC Controller is a Safety Class I instrument, which means it has a protective earth terminal. That terminal must be connected to earth ground through a power source equipped with a ground receptacle. The protective earth ground is the ground on the 3-pin AC input connector. There is also a second functional earth ground stud that should be connected to the rack chassis ground the equipment is mounted to.



WARNING:

Hazardous voltages exist at the output. AC power should be turned off to the unit before making or removing connections to the rear panel. Product should only be installed by trained personnel, and output connections should not be accessible by users. Output wiring insulation must be rated for greater than or equal to the maximum output voltage.

4.4 Typical System Connections

Figure 4-1 shows a typical system setup of an eH-HC controller with an end hall ion source and hollow cathode.

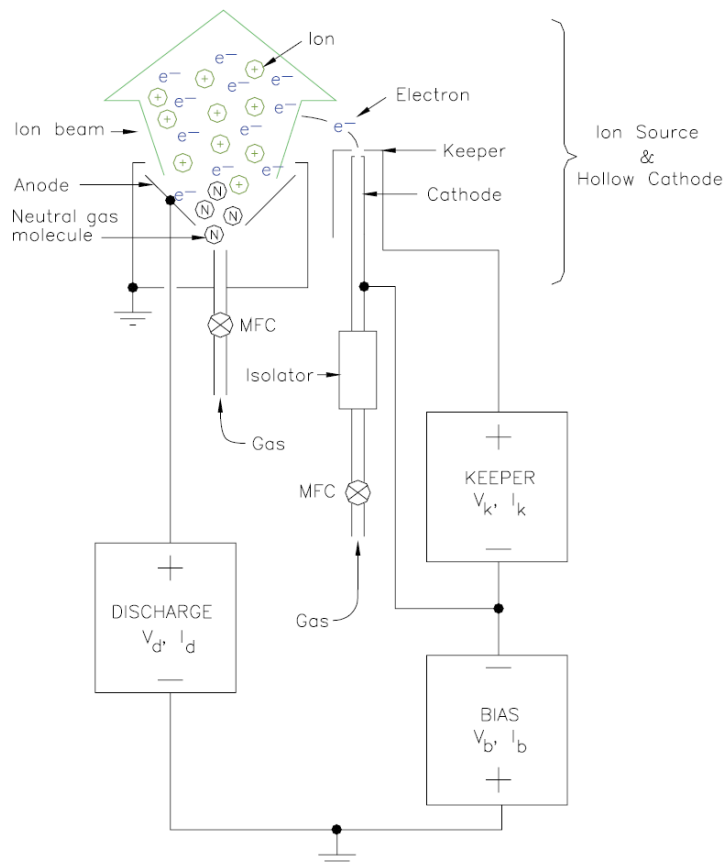

Figure 4-1. eH-HC controller system setup.

INSTALLATION

4-3

4.5 Electrical Connections

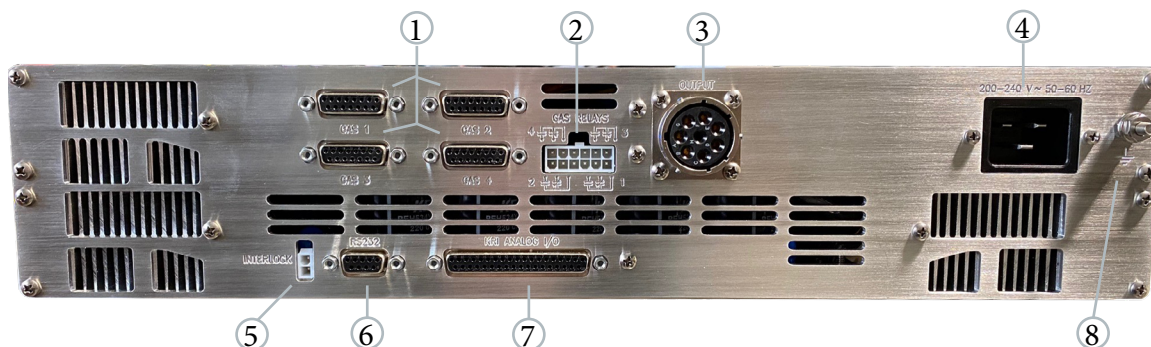

Table 4-2. Back panel descriptions.

Item #	Description	Connector Info
1	Gas MFC Control GAS1-GAS4	D-sub 15 pin female
2	Gas Valve Relay Control	Molex 12 pin Mini-Fit Jr Mating Connector = Molex 39-01-2120 Mating Connector Pins = Molex 39-00-0039 (24-18 AWG wire)
3	Output Connector (Discharge, Keeper, Emission Output)	Connector = Deutsch MS470L-18-8S Mating Connector = Deutsch MS475L-18-8P
4	AC Input	IEC C20, 3 pin male Mating Connector = IEC 60320 C19, 3-pin female
5	Interlock	2-pin Molex
6	RS-232 Remote Com Port	D-sub 9-pin female
7	KRI® Analog Remote Port - DB-37	D-sub 37-pin female
8	Earth Ground Stud	10-32 Threaded Stud

4.5.1 MFC Control Connectors

The eH-HC Controller can control four analog MFCs via the four DB-15 female connectors on the rear panel. The description of these pins is shown below.

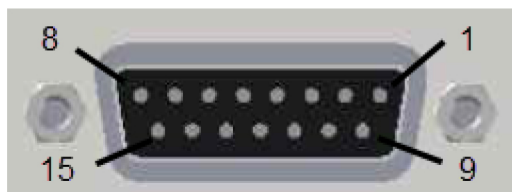

Table 4-3. DB-15 Analog MFC Connector Pinout

Pin	Name	Description
1	GND_ISO	Ground reference for the analog setpoints and readbacks.
2	GAS_READBACK	Analog Gas Readback, referenced to GND_ISO. Scaled 0 to 5V equals 0 to MFC Channel Max.
3	No Connect	Reserved for future digital MFC receive channel. Currently not used.
4	VALVE_OFF	Connected to GND_ISO when MFC setpoint is set to zero or when unit is in the standby mode, otherwise connected to +5V.
5	+15V	+15V supply, referenced to pin 9 (CHASSIS_GND). Max current = 1.5A total for all × 4 MFC connectors
6	-15 V	-15V supply, referenced to pin 9 (CHASSIS_GND). Max current = 1.5A total for all × 4 MFC connectors.
7	No Connect	
8	G A S _ S E T - POINT_OUT	Analog setpoint output, scaled 0 to 5V equals 0 to MFC Channel Max, referenced to GND_ISO.
9	CHASSIS_GND	Power/chassis ground.
10	GND_ISO	Ground reference for the analog setpoints and readbacks.
11	No Connect	
12	No Connect	
13	No Connect	Reserved for future digital MFC transmit channel. Currently not used.
14	No Connect	
15	No Connect	

INSTALLATION

4-5

4.5.2 Gas Valve Relay Connector

The eH-HC Controller has additional relay outputs for controlling a positive shut-off value for the MFC. The 12 pin connector contains both N.O. (normally open) and N.C. (normally closed) contacts.

These pins are operated in conjunction with the gas setpoint. If the MFC is given a setpoint, then the state of the relay contacts are toggled. If there is no gas setpoint (output disabled), then these contacts will be in their default state.

The back panel of the unit has the common, normally open, and normally closed contacts clearly marked for ease of use, but are described below as well.

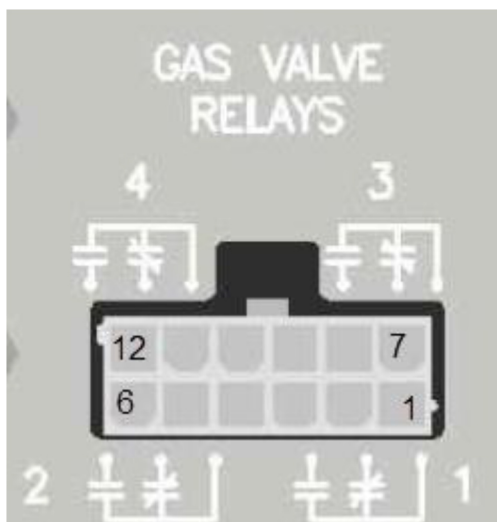

Pin	Description
1	Gas Valve Relay 1 common
2	Gas Valve Relay 1, N.C. contact
3	Gas Valve Relay 1, N.O. contact
4	Gas Valve Relay 2 common
5	Gas Valve Relay 2, N.C. contact
6	Gas Valve Relay 2, N.O. contact
7	Gas Valve Relay 3 common
8	Gas Valve Relay 3, N.C. contact
9	Gas Valve Relay 3, N.O. contact
10	Gas Valve Relay 4 common
11	Gas Valve Relay 4, N.C. contact
12	Gas Valve Relay 4, N.O. contact

4.5.3 Output Connector



WARNING:

Hazardous voltages exist at the output. AC power should be turned off to the unit before making or removing connections to the rear panel. Product should only be installed by trained personnel and output connections should not be accessible by users. Output wiring insulation must be rated for greater than or equal to the maximum output voltage.

The output connector has two connections for each supply output; it is recommended that both of these connections be used to handle the full supply output current.

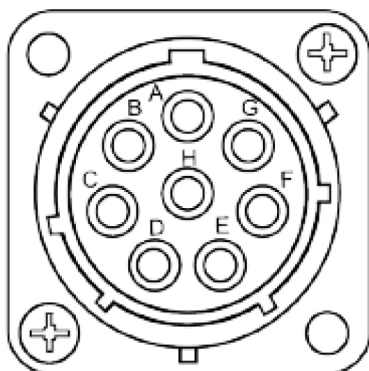

Pin	Description
A	Discharge Positive (anode)
B	Emission Negative
C	Discharge Negative (common)
D	Emission Negative
E	Discharge Negative (common)
F	Keeper Positive
G	Keeper Positive
H	No Contact

4.5.4 AC Input Connector and Earth Ground Stud



CAUTION:

Applying incorrect AC mains voltage or incorrectly wiring to the AC mains will damage the controller and void the warranty. Connection to an AC power source must be made by qualified personnel in accordance with local electrical codes.

The eH-HC Controller uses an IEC 60320 C20 connector for the single phase AC input. The mating connector should be an IEC C19 plug and the power cord should be made of 12 AWG wire or equivalent. Single phase 200 – 250 V AC should be applied to the two non-green

INSTALLATION

4-7

wires in the power cord. This can also be accomplished by connecting across 2 phases of a 208 V 3 phase system.

The power cord provides the protective earth connection to the chassis. The ground conductor in the power cord must be connected to earth ground for safety. The power cord is supplied with a pigtail on one end for the user to be able to connect to AC power as needed.

A second functional earth ground stud (10-32) is also provided. This should be connected to the local ground of the equipment rack in which the eH-HC Controller is mounted. It should be connected via 12 AWG wire or equivalent.

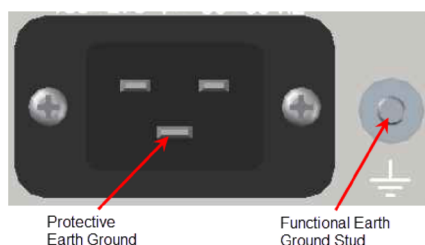

4.5.5 RS-232 COM PORT

The RS-232 port is a DB9 connector with the typical pin out as shown below. A quality shielded cable with proper 360 degree shield terminations should be used to comply with radiated emissions standards.



Pin	Description
1	No Contact
2	RS232 TXD
3	RS232 RXD
4	No Contact
5	Ground
6	No Contact
7	No Contact
8	No Contact
9	No Contact

4.5.6 DB-37 KRI® Analog Port

The KRI® DB-37 analog port is used for analog remote control of the product. The connector is a DB-37 in female.



4.5.7 Interlock

The eH-HC Controller provides two pins for an interlock to disable the units power outputs. The interlock consists of a 2-pin Molex connector at the rear of the unit. When these two pins are tied together, the interlock is satisfied.

DO NOT attempt to satisfy the interlock by shorting either of the two pins to ground as this will cause the unit to malfunction and possibly damage the unit as well. These two pins must be connected with a floated contact.



WARNING:

Interlock lines are not intended for the protection of human life. AC power should be removed before servicing the product.

5. LOCAL OPERATION

The eH-HC Controller has a front panel user interface for simple operation that requires no additional hardware or programming. The following sections describe the basic menus of the front panel user interface as well as front panel operation. Names of buttons and menu parameters are shown in bold text.

The unit can store up to 4 different operational programs. A program is a collection of output operating parameters such as discharge voltage and current, emission current, and flow values. This collection of parameters is then stored as a single program.

5.1 Front Panel User Interface

The front panel user interface contains two 4×40 LCD character displays. These two displays operate together as a single display rather than individually. When a menu screen is changed both displays will change together. The two displays will be referenced as the LEFT display and RIGHT display while looking at the front of the unit. The front panel user interface has six main screens which are accessed by changing the **Display** parameter. The screens are navigated by using the **Item Select** button and the **Item Select** button in conjunction with the **Adjust** knob. Program setpoint parameters can be saved or recalled using the **Program Load/Save** button. The output is enabled and disabled using the **Output Enable/Standby** button. The menus and buttons are described in more detail in the following sections.

5.2 Front Panel User Interface - Basic Operation

The front panel operation is intuitive, but there are a couple of items which require some basic instruction in order to navigate the front panel.

The cursor for the screen is shown by flashing the parameter to be changed. To move the cursor press the **Item Select** button to advance through the parameters. This only works for the program setpoint parameters. To move the cursor to the **Control**, **Remote**, and **Display** parameters you must turn the **Adjust** knob counterclockwise while pressing and holding the **Item Select** button. This is because the user should not regularly need to access these settings once the unit has been configured for the specific installation.

Note: the **Remote** and **Display** parameters cannot be accessed when the output is on.

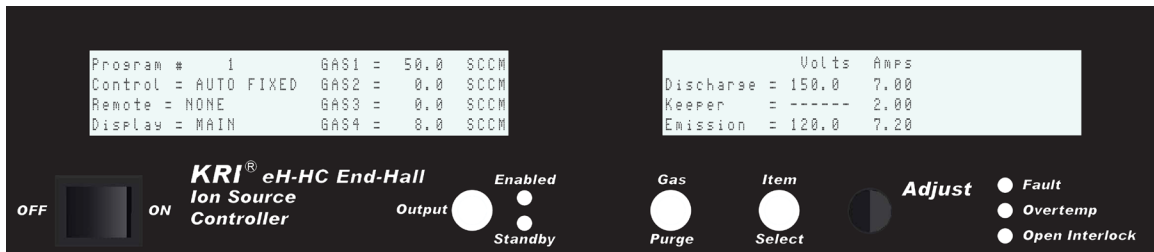

To change programs or program setpoint parameters press the **Item Select** button to advance through the menu to the desired parameter then use the **Adjust** knob to change the value up or down. Once a value has been changed, you will see the **Program #** field change to “CHANGED” indicating a current setpoint has been modified from the stored program value.

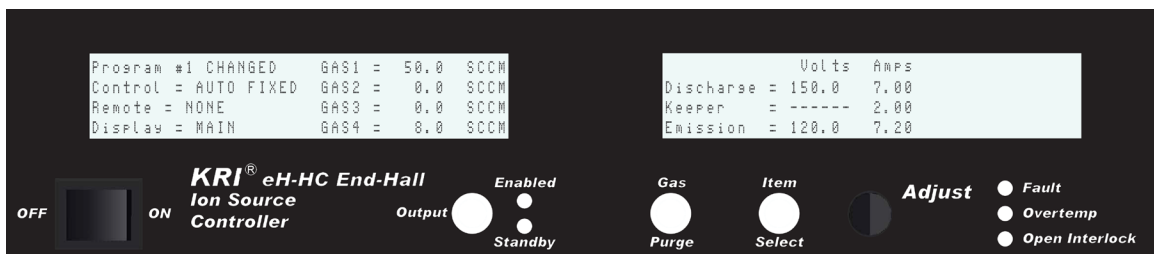

Once all program setpoint values have been set, press the **Item Select** button to advance through the menu back to the **Program #** field. Once the **Program #** field is blinking, press the **Program Load/Save** button to save all values to the specified program number.

Note: pressing the **Program Load/Save** button outside of the **Program #** field will reload the saved program number values and discard any changes that were made. You will then see the **Program #** field text change back to the program number 1 – 4.

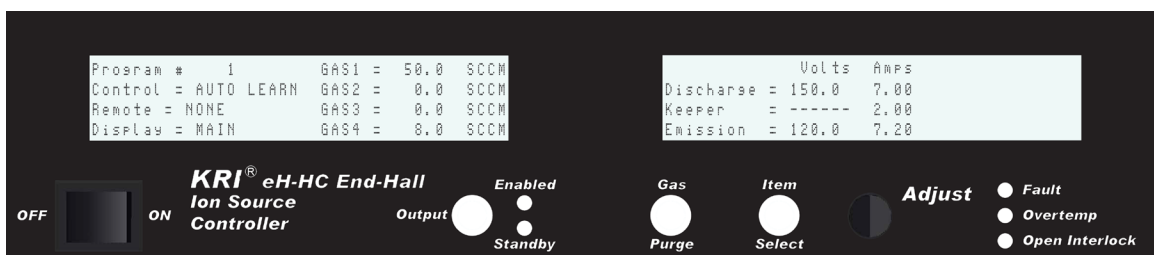

LOCAL OPERATION

5-3

5.3 DISPLAY Screens

The front panel user has seven main screens. These seven screens are accessed by changing the **Display** parameter. The display parameter can only be accessed by turning the **Adjust** knob while pressing and holding the **Item Select** button.

Note: the **Display** parameter cannot be accessed when the output is on. The seven main windows are described below.

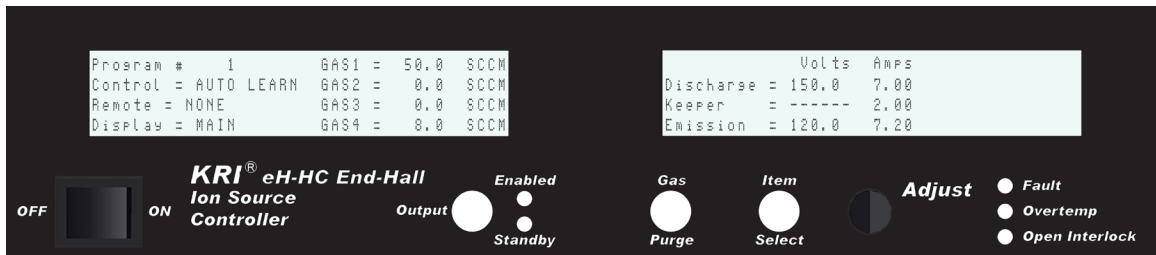

5.3.1 Display - MAIN Screen

The **MAIN** screen is shown below. This is the main screen for operating the unit. The **Remote** mode, **Control** mode, and all **Program #** setpoint values are all accessed via this screen. This is the only screen which allows you to enable the outputs to run the unit with an ion source.

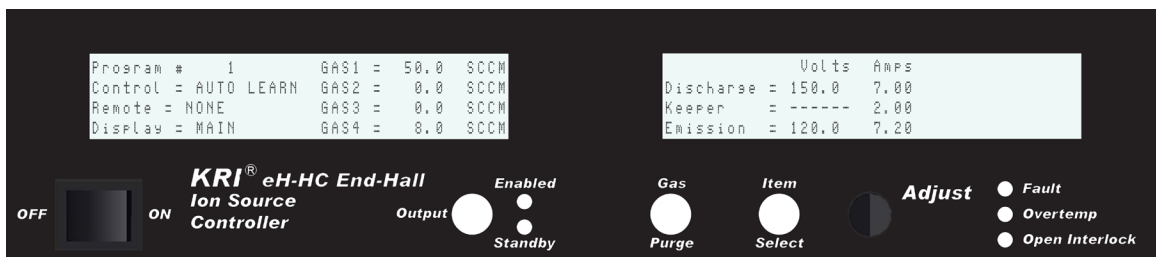

5.3.2 Display - SETUP ONE

The second screen in the **Display** menu is the **SETUP ONE** screen shown below. This screen contains the **Gas Pre-flow** and **Post-flow** times, **RS-232 Baud Rate**, **P35 Enable**, **Learn** function, and the **Heartbeat Timer** settings.

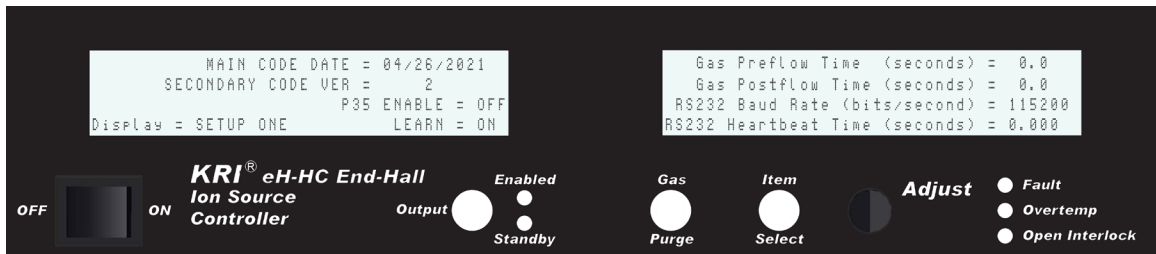

Gas Pre-flow Time: This parameter sets the amount of time in seconds gas is allowed to flow after receiving an output enable before the discharge, keeper and emission supplies are enabled. This can aid in ignition by helping to make sure there is sufficient gas to the source before the discharge supply is enabled.

Gas Post-flow Time: This parameter sets the amount of time in seconds gas is allowed to flow after receiving an output disable (standby).

RS232 Baud Rate: This parameter sets the baud rate in bits/second for RS-232 communication.

RS232 Heartbeat Time: This parameter sets the time in seconds for the RS-232 heartbeat timer. Setting the value to zero will disable this feature. The heartbeat time is the time allowed between receiving RS-232 commands before faulting. The heartbeat timer is only functional in RS232 ACTIVE remote mode. The heartbeat timer starts when the <COM:1> command is received after the unit has been set to RS-232 remote mode. If a valid RS-232 command is not received within this timeout value the unit will fault with error HELP 23 and disable the output. To reset the timer you must send COM:0 to take the unit out of RS-232 Active control and clear the fault, then resend COM:1 to re-enable RS-232 Active control.

P35 Enable: This parameter enables different gas ratios to be set using pin 35 on the back analog DB37 port. For P35 applications contact KRI for details.

LOCAL OPERATION

5-5

Learn: Toggles the “Learn” function that automatically adjusts and saves gas setpoints to reach the desired operating conditions set by the user.

5.3.3 Display - DISCHARGE

The **DISCHARGE** screen is a debug troubleshooting mode for running the discharge supply only. The gas flow channels and other supplies are not enabled when the output is enabled in this screen. The only settable parameters are discharge voltage and current.

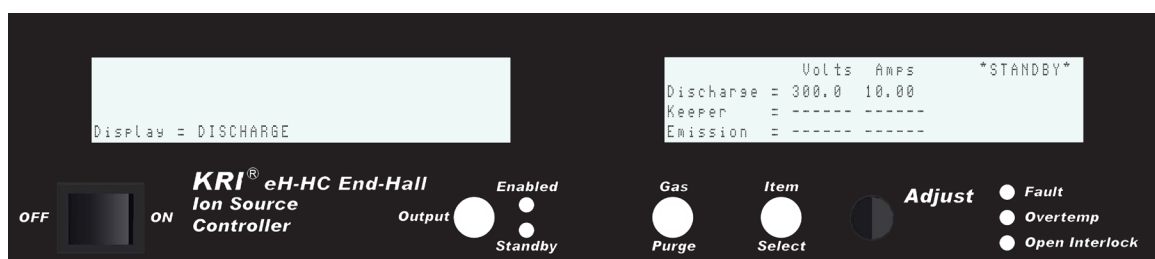

5.3.4 Display - KEEPER

The **KEEPER** screen is a debug troubleshooting mode for running the keeper supply only. The gas flow channels and other supplies are not enabled when the output is enabled in this screen. The only settable parameters are keeper voltage and current.

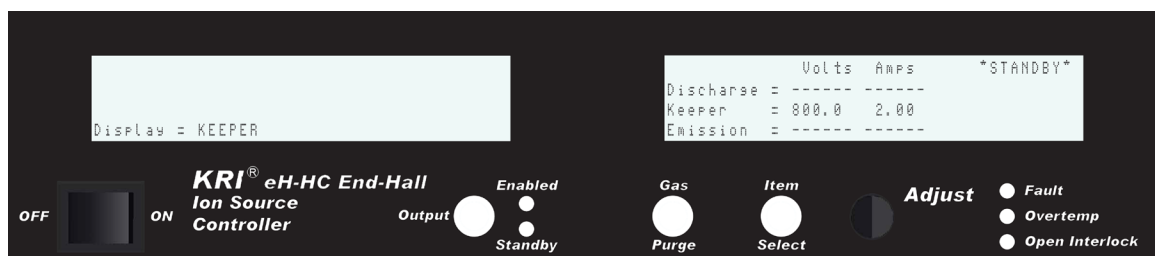

5.3.5 Display - EMISSION

The **EMISSION** screen is a debug troubleshooting mode for running the emission supply only. The gas flow channels and other supplies are not enabled when the output is enabled in this screen. The only settable parameters are emission voltage and current.

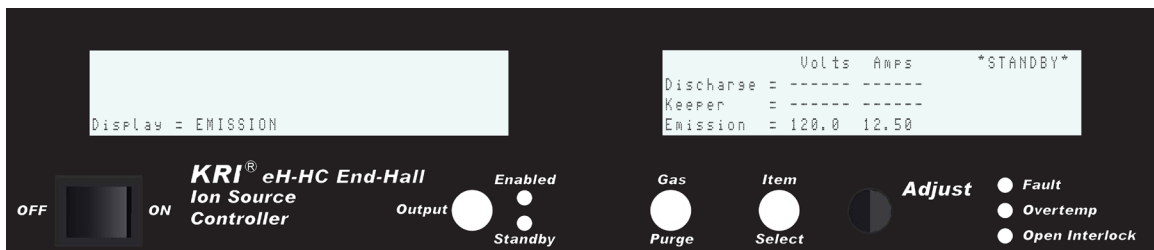

5.3.6 Display - STATUS

The **STATUS** screen has some basic readback information on the unit such as thermistor **Temperatures**, **AC Line Voltage**, **Line Frequency**, main DC **Bus Voltage**, and the **Gate Drive Voltage**. There are no settable parameters on this screen, it contains readbacks only.

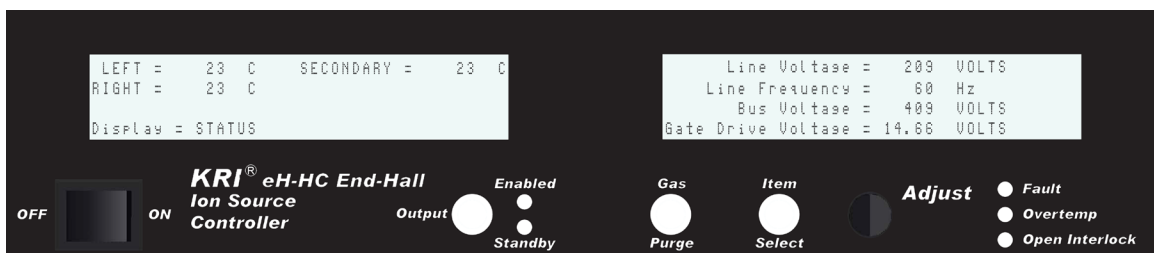

5.3.7 Display - SETUP TWO

The **SETUP TWO** screen is used for setting all the parameter maximums, filament bias, and the regulation mode threshold. This screen is typically accessed during the initial configuration of the unit for a given source or process then left alone. This screen allows you to enable/disable gas channels, set the maximum values for **Gas1**, **Gas2**, **Gas3**, **Gas4**, **Discharge Voltage**, **Discharge Current**, **Keeper Voltage**, **Keeper Current**, **Emission Voltage**, **Emission Current**, **HC Joules**, **HC Watts**, and finally the **Reg Mode Voltage**.

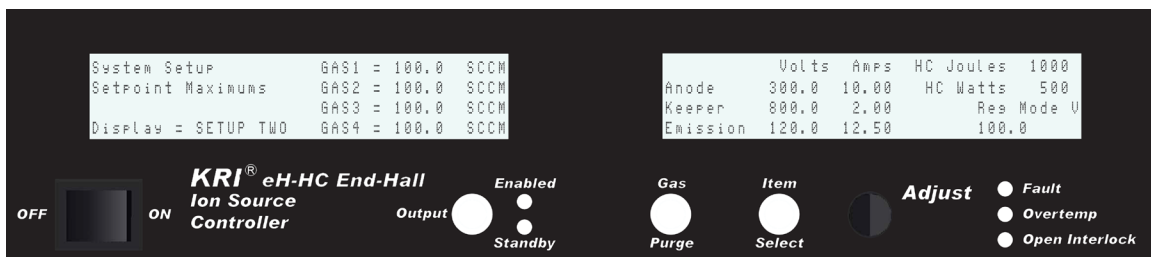

Setpoint Maximums: The maximum settings determine the maximum allowed setpoints. Changing these values will also rescale the analog inputs and outputs. For example if the discharge voltage maximum is changed from 300 V to 200 V then the analog inputs and outputs will rescale from 5 V/300 V to 5 V/200 V.

GAS1 – 4 Setting: Setting the max flow to 0 for the gas channel will change the value to OFF. When gas channels are set to OFF the user can not set any setpoints in the Main window and the cursor will skip over these parameters. Sending RS-232 P: commands for gas setpoints to a disabled (OFF) gas channel will respond with an error 99 (value larger than max setting).

HC Joules: This sets the maximum energy allowed for the hollow-cathode during start before the unit errors to a “start-fault” condition. This value only applies while the unit is in the start up sequence.

HC Watts: This sets the maximum power allowed to the hollow-cathode while running. Once the Keeper Supply exceeds this power setpoint, the unit will track the energy (joules) output until a “run-fault” condition is displayed. The further this setpoint is exceeded, the faster the energy (joule) counter is accumulated and the “run-fault” condition is set.

Reg Mode V: This is setting the voltage threshold used to determine whether the discharge supply operates in either voltage or current mode regulation. This is used by the control loop when the eH-HC controller is operated in Auto Fixed or Auto Learn Control modes. The default value is 100 V. This voltage threshold is set at the factory and is typically not changed except in special cases in which KRI technical support is working closely with the customer.

When the Discharge voltage setpoint is greater than the Reg Mode V threshold, the unit will operate in voltage regulation mode and the gas flow will be changed by the control loop to meet the desired Dis-

charge current.

When the Discharge voltage setpoint is less than or equal to the Reg Mode V threshold, the unit will operate in current regulation mode and the gas flow will be changed to meet the desired Discharge voltage.

5.4 REMOTE Parameters

There are four **REMOTE** modes. This value can only be set via the front panel. The remote mode determines how the eH-HC Supply is controlled by the user such as local front panel control, analog control, or RS-232 control. There are several analog control modes allowing analog control to be performed using preset stored program values where only the enables are remotely controlled, or full analog control with all setpoints remotely controlled as well. There is one analog port, the DB-37 KRI® port. The REMOTE parameters are described in detail below.

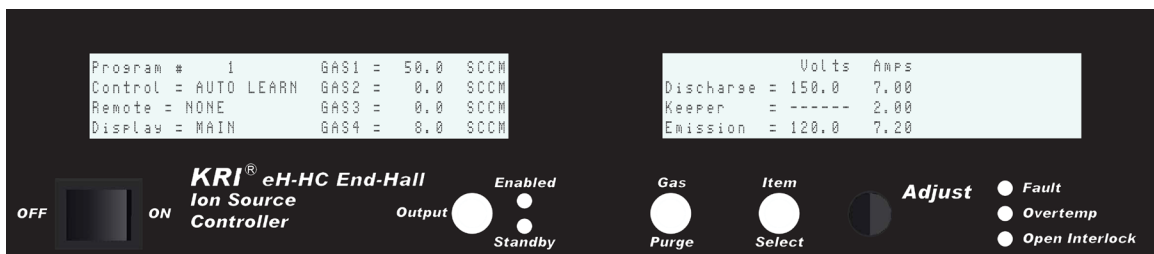

5.4.1 NONE - Local Mode

The **NONE** mode is for local front panel control. Only front panel control can be used. Setpoints and readbacks can still be queried or read at the RS-232 port, but the unit will not accept setpoints or respond to enables from this port. Readbacks only are available at the DB-37 analog port, but the unit will not accept setpoints or respond to enables from these ports.

5.4.2 ENABLE DB37

The **ENABLE DB37** remote mode is for using the DB-37 KRI® port for remote enable and program number selection. In this mode, only the output enable and program select pins are remoted. All setpoints come from stored programs 1 – 4. The program values are setup via the front panel interface. The programs are then selected via two pins on the DB-37 port. See Table 6-1 that defines the DB-37 port pins for

more details.

5.4.3 ALL DB37

The **ALL DB37** remote mode is for using the DB-37 KRI[®] port for full analog control. In this mode, the output enable and all setpoints are remoted giving the user full access to all parameters. The program select pins are ignored in this mode since analog setpoints are used rather than the stored program values. See the table defining the DB-37 port pins for more details.

5.4.4 RS-232

The **RS-232** mode is used to enable RS-232 control. This initial setting only allows the unit to be put into RS-232 control. The unit will not accept setpoints via the RS-232 port in this mode. The user must send the <COM:1> command after placing the unit in RS-232 mode which will then change the mode to RS-232 ACTIVE mode for RS-232 control. The user will then be locked out of front panel control.

5.4.5 RS-232 ACTIVE

The unit is placed into **RS-232 ACTIVE** mode after receiving a <COM:1> command while the unit is in remote mode RS-232. The unit will now accept setpoints and enable commands via the RS-232 port. The user will no longer have front panel access until a <COM:0> command is received or the AC power is cycled. If the AC power is cycled then the user must resend the <COM:1> command to re-enter RS-232 ACTIVE mode.

5.5 CONTROL Parameters

There are four **CONTROL** mode parameters to choose from. The **CONTROL** mode parameter defines the operation of the system control loop. This value can only be set via the front panel. The optional parameters are described below. The unit should typically be run in **AUTO LEARN** mode for normal processes. The manual mode is typically for debug or initial understanding of process parameters. Once desired setpoints are understood the unit should be run in one of the **AUTO** modes.

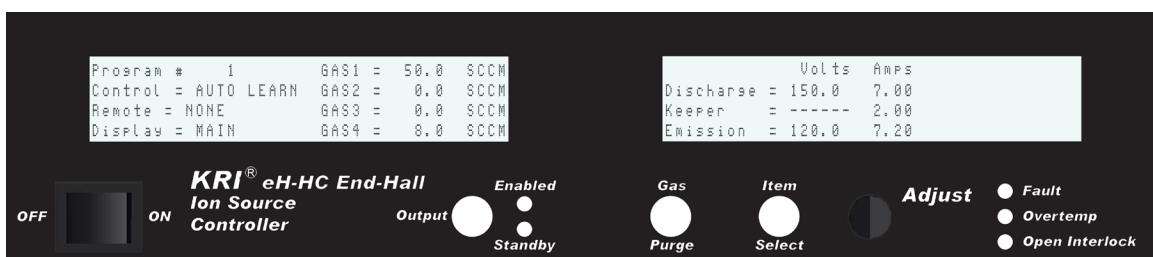

5.6 MANUAL Control

In **MANUAL** control mode the user sets the desired initial gas setpoints, discharge voltage or discharge current setpoints, etc. In this mode the system control loop does not adjust the gas flow to meet the desired discharge voltage and current setpoints. Instead the user selects **either** a discharge/emission voltage or discharge/keeper/emission current setpoint. The user then **manually** adjusts the gas flow to cause the plasma impedance to change, therefore adjusting the other discharge parameter to the desired value. For example set 150 V discharge voltage and set the discharge current to maximum of 10 A. Enable the output and manually adjust the gas flow up or down to meet your target discharge current.

Note: the Manual mode still sequences the outputs on enable/disable and includes the auto ignition sequence at the beginning to aid in igniting the source.

This mode is intended for debug or identifying desired operating values before setting up the **AUTO** mode.

5.7 AUTO FIXED/LEARN Control

AUTO LEARN and **AUTO FIXED** are toggled by the **LEARN** function in **SETUP ONE**. If **LEARN** is set to **OFF**, only **AUTO FIXED** will be avail-

LOCAL OPERATION

5-11

able on the front panel for auto control. If **LEARN** is set to **ON**, only **AUTO LEARN** will be available on the front panel for auto control.

In **AUTO FIXED** control mode the user sets the desired initial gas setpoints, discharge voltage, discharge current, and keeper/emission setpoints. When the output is enabled the unit will automatically adjust the gas flow to change the plasma impedance for the desired discharge voltage and current setpoints. No user adjustments are required. If the source has difficulty igniting, the eH-HC controller will go through an advanced ignition sequence to aid the plasma ignition. If it is still unsuccessful the unit will fault with a start fault.

The **AUTO LEARN** control mode is exactly the same as the **AUTO FIXED** with one exception. The **AUTO LEARN** mode will remember the final operating gas setpoint required for operation at the requested discharge setpoints and then use this value for the initial gas setpoint on future runs. This increases the speed at which the eH-HC Controller and the source reach the desired operational values.

The gas learn function does not apply for full analog control modes where the user has full access to the setpoints remotely. It is assumed the user will make the appropriate setpoint changes in these situations. If the user wishes to implement the learn mode, then the final gas setpoints should be queried from the unit once the unit has reached a stable operating point. These setpoints would then be saved and sent to the unit to be used for the next run.

5.8 GAS ONLY Control

The **GAS ONLY** control mode is just as it sounds. It is used to run the controller solely as a gas flow controller for MFCs. The Discharge, Keeper, and Emission supplies are disabled in this mode.

5.9 HC ONLY

The **HC ONLY** control mode allows for the Hollow Cathode (HC) to be run by itself. In this mode the Discharge supply is disabled while the Keeper and Emission supplies remain active. Using the **Item Select** button on the front panel, you are still able to make adjustments to the gas setpoints, Keeper current, and Emission voltage/current setpoints. The power supply will still follow that same start up sequence where the Keeper supply will attempt to light the HC and the Emission supply will be enabled once the HC is lit.

This Page is Intentionally Blank

REMOTE CONTROL

6-1

6. REMOTE CONTROL

The eH-HC Controller can be controlled remotely by analog 0 – 5 V signals on the DB-37 KRI® Analog interface or digitally via the RS-232 interface.

To use remote control the unit must be set to the correct **REMOTE** mode via the front panel as described in front panel interface Section 5.4 REMOTE Parameters.

6.1 Analog Control

For analog control the KRI® DB-37 interface is used.

6.1.1 KRI® DB-37 Analog Interface

To use the KRI® DB-37 analog interface the unit must first be put in to either **ENABLE DB37** or **ALL DB37** remote mode via the front panel. See front panel user interface section 5.4 REMOTE Parameters for details.

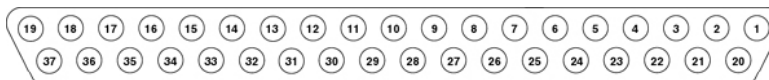

DB-37 Pin Identifier

Table 6-1. KRI® DB-37 Analog Remote Pinout

Pin	Name	Type	Description
1	EEI_Readback	Output	Emission current readback. Referenced to GND_ISO. eH-HC3005 = scaled 5 V/6 A ¹ eH-HC30010 = scaled 5 V/12.5 A ¹
2	KPV_Readback	Output	Keeper Voltage readback. Referenced to GND_ISO. Scaled 5 V/800 V ¹
3	DSV_Setpoint	Input	Discharge voltage setpoint. Referenced to GND_ISO. Scaled 5 V/300 V ¹
4	EEI_Setpoint	Input	Emission current setpoint. Referenced to GND_ISO. eH-HC3005 = scaled 5 V/6 A ¹ eH-HC30010 = scaled 5 V/12.5 A ¹

6-2

REMOTE CONTROL

Pin	Name	Type	Description
5	+12V_ISO	Output	+12 V unregulated supply referenced to GND_ISO. Maximum current = 50 mA
6	EEV_Readback	Output	Emission voltage readback. Referenced to GND_ISO. Scaled 5 V/120 V
7	No Connect		
8	GND_ISO	GND	Isolated ground for analog setpoints and readbacks.
9	GAS1_Readback	Output	Gas 1 readback. Referenced to GND_ISO. Scaled 5 V/max gas flow for channel.
10	GAS3_Readback	Output	Gas 3 readback. Referenced to GND_ISO. Scaled 5 V/max gas flow for channel.
11	GAS1_Setpoint	Input	Gas 1 setpoint. Referenced to GND_ISO. Scaled 5 V/max gas flow for channel.
12	GAS3_Setpoint	Input	Gas 3 setpoint. Referenced to GND_ISO. Scaled 5 V/max gas flow for channel.
13	GND_ISO	GND	Isolated ground for analog setpoints and readbacks.
14	GAS3_Enable/Disable	Input	Gas 3 enable/disable.
15	GAS4_Enable/Disable	Input	Gas 4 enable/disable.
16	PROGRAM_SEL_0	Input	This pin is used in conjunction with the PROGRAM_SEL_1 pin 34 to select a program number set via the front panel. Referenced to GND_ISO. See Table 6-2 below for more details.
17	No Connect		
18	No Connect		
19	FAULT	Output	FAULT pin will go high +5 V whenever there is an active fault. Referenced to GND_ISO.
20	DSI_Readback	Output	Discharge current readback referenced to GND_ISO. eH-HC3005 = scaled 5 V/5 A ¹ eH-HC30010 = scaled 5 V/10 A ¹

Copyright © 2021 by Kaufman & Robinson, Inc., 1330 Blue Spruce Drive, Fort Collins, CO 80524
 Tel: 970-495-0187, Internet: www.ionsources.com

REMOTE CONTROL

6-3

Pin	Name	Type	Description
21	DSV_Readback	Output	Discharge voltage readback, referenced to GND_ISO. Scaled 5 V/300 V ¹
22	DSI_Setpoint	Input	Discharge current setpoint, referenced to GND_ISO. eH-HC3005 = scaled 5 V/5 A ¹ eH-HC30010 = scaled 5 V/10 A ¹
23	BEAM_GOOD_1	Output	Relay contact, connected to BEAM_GOOD_2 when the following are true: <ul style="list-style-type: none"> • Discharge Voltage within +/- 10 V of setpoint • Discharge Current within +/- 0.5 A of setpoint • Emission Current within 75% of setpoint Note: BEAM_GOOD_1 is always connected to BEAM_GOOD_2 when in Manual, Discharge Only.
24	BEAM_GOOD_2	Output	Relay contact, connected to BEAM_GOOD_1 when the following are true: <ul style="list-style-type: none"> • Discharge Voltage within +/- 10 V of setpoint • Discharge Current within +/- 0.5 A of setpoint • Emission Current within 75% of setpoint Note: BEAM_GOOD_2 is always connected to BEAM_GOOD_1 when in Manual, Discharge Only.
25	KPV_Readback	Output	Keeper voltage readback, referenced to GND_ISO. Scaled 5 V/800 V ¹
26	KPI_Setpoint		Keeper current setpoint, referenced to GND_ISO. Scaled 5 V/2 A ¹
27	GND_ISO	GND	Isolated ground for analog setpoints and readbacks.
28	GAS2_Readback	Output	Gas 2 readback. Referenced to GND_ISO. Scaled 5 V/max gas flow for channel.
29	GAS4_Readback	Output	Gas 4 readback. Referenced to GND_ISO. Scaled 5 V/max gas flow for channel.
30	GAS2_Setpoint	Input	Gas 2 setpoint. Referenced to GND_ISO. Scaled 5 V/max gas flow for channel.
31	GAS4_Setpoint	Input	Gas 4 setpoint. Referenced to GND_ISO. Scaled 5 V/max gas flow for channel.

Pin	Name	Type	Description
32	GAS1_Enable/Disable		Gas 1 enable/disable.
33	GAS2_Enable/Disable		Gas 2 enable/disable.
34	PROGRAM_SEL_1	Input	This pin is used in conjunction with the PROGRAM_SEL_0 pin 16 to select a program number set via the front panel. Referenced to GND_ISO. See Table 6-2 below for more details.
35	P35_INPUT		P35 pin function.
36	ENABLE	Input	Output enable. Connect to GND_ISO to enable the output. Leaving open will disable the output. Pin is pulled high via 10 K to +5 V internally to default it to an off state.
37	KPI_Readback		Keeper current readback, referenced to GND_ISO. Scaled 5 V/2 A ¹

Note: If the maximum value for the parameter has been decreased as described in front panel interface section 5.3.6 Display – Setup Two 5.3.6, then the analog scaling will automatically change to 0 - 5 V = 0 to the new maximum.

Table 6-2. Remote Program Select Table

Program #	PROGRAM_SEL_1 pin 34	PROGRAM_SEL_0 pin 16
1	Open	Open
2	Open	GND ISO
3	GND ISO	Open
4	GND ISO	GND ISO

6.2 RS-232 Control

The eH-HC Controller can be controlled digitally via the RS-232 DB-9 port using simple ASCII commands. The default com port settings are shown below. The baud rate can be changed by going to the **SETUP ONE** menu via the front panel as described in front panel user interface Section 5.3.2 Display – SETUP ONE. A straight-through type DB9 cable should be used between the PC/PLC and the unit.



DB-9 Pin Identifier

Default RS-232 Port Settings

Baud Rate = 115200
Data Bits = 8
Parity = None
Stop Bits = 1
Flow Control = None

Pin	Description
1	No Contact
2	RS232 TXD
3	RS232 RXD
4	No Contact
5	Ground
6	No Contact
7	No Contact
8	No Contact
9	No Contact

6.2.1 RS-232 Command Overview

The following conventions are used for the command and query descriptions in the following sections:

- “ ” – Text or numerical values inside double quotation marks indicate the exact response from the controller.
- < > - Text inside angle brackets indicates parameters that are included with a command. The brackets are not included when actually issuing the command.
- () – Parentheses are used to denote number values which are

REMOTE CONTROL

6-6

sent to the unit for setpoint commands. The parentheses are not included when actually issuing the command.

All commands are UPPERCASE sensitive. Lowercase values will be interpreted as invalid commands.

All commands must be terminated with a carriage return character. A carriage return is ASCII 13 or hex 0x0D. Carriage returns will be indicated as <cr> throughout the manual. If a command is sent without a carriage return it will not be acted upon and no response will be sent. The unit will eventually respond with error 19 (invalid command) once the buffer fills up with unterminated commands.

All commands that have a response and are terminated with a carriage return <cr> and a line feed <lf> . A line feed is ASCII 10 or hex 0x0A. Line feeds will be indicated as <lf> throughout the rest of the manual. For set commands which do not return data they will respond with "OK" followed by a <cr><lf>.

If the RS-232 command is not accepted the unit will respond with "ERROR" followed by the error number which is defined in the <HELP> command. Example Error Response: "Error 19"

6.2.2 RS-232 Command List

Enter (Carriage Return) – Command List:

Sending a carriage return <cr> hex 0xD will return a text list of all commands for the product.

Example: <cr>

Response:

```
COMMANDS|QUERIES |READBACKS
|        |
COM:0 |COM? |TEMP1
COM:1 |*IDN? |TEMP2
ECHO |*RST? |TEMP3
OUT:0 |*TST? |BUSV
OUT:1 |OUT? |LINEV
|BEAM? |
|DIS? |
|EEI? |
|MDE? |
|HELP |
Note: x = program number below
Px = P0, P1, P2, P3, or P4
|        |
Px:GS1 |Px:GS1? |R:GS1
Px:GS2 |Px:GS2? |R:GS2
Px:GS3 |Px:GS3? |R:GS3
Px:GS4 |Px:GS4? |R:GS4
Px:DSV |Px:DSV? |R:DSV
Px:DSI |Px:DSI? |R:DSI
Px:EEI |Px:EEI? |R:EEI
Px:EEV |Px:EEV? |R:EEV
Px:KPI |Px:KPI? |R:KPI
| |R:KPV
Px:ALL |Px:ALL? |R:ALL
```

REMOTE CONTROL

6-8

HELP: - Error List

Sending the HELP command will return a list of all error and fault codes.

Example: HELP<cr>

Response:

“HELP/ERROR # Definitions

2 Thermal Fault (Broken Thermistor)

3 HC Start Fault

4 Low line voltage

5 Low Bus Voltage

10 Start Fault

11 Run Fault

12 Gas Fault

13 Front Panel Com Fault

16 Gate Drive Voltage Fault

17 Interlock Fault

18 Overtemp Fault (wait for unit to cool)

19 Invalid RS232 Command

20 Needs to be in Remote and Standby

21 Wrong Data Format

22 Data too Large

23 RS-232 Heartbeat Timeout Fault

32 HC Run Fault

33 Readback Fault

34 Pulse Calc Link Fault

35 Setpoints Link Fault

36 Status Link Fault

64-70 P:ALL parameter position of incorrect setpoint

99 Value Larger than Max Setting

102 Discharge Current Latch

103 Keeper Current Latch

104 Emission Current Latch

112 Secondary In Boot

666 Needs to be in Standby for Reconfiguration

***IDN?:**

The *IDN? command will return the product type and code revision of month/day/year.

Example: *IDN?<cr>

Response: “KRI:eHC30010 - 4/16/2021”

ECHO:

The ECHO command will cause the unit to return (echo) back each character that is sent to it. This can be used for debug or error checking if needed. Once the ECHO command is sent, the unit will remain in this mode until it is reset by an AC power cycle or by the *RST command.

***RST:**

The *RST reset command will turn ECHO off. If the unit is in RS-232 ACTIVE remote mode (6) then it will also take the unit out of RS-232 ACTIVE control and return to RS-232 ready mode (5) and allow front panel access to the user.

COM:

The COM: command is used to enable and disable RS-232 control. To put the unit into RS-232 control the unit must first be set to Remote mode = RS-232 and the unit must be in Standby (output off). Then the COM:1 command is sent to put the unit in Remote mode = RS-232 ACTIVE mode(6). Sending a value of 0 will disable RS-232 ACTIVE mode and return the unit to RS-232 ready mode (5) and allow front panel access.

Example: COM:<1><cr>
Response: "OK"<cr><lf>

Example response when unit is not in RS232 ready mode(3) and Standby.

Example: COM:1
Response: "ERROR 20"<cr><lf>

COM?:

The COM? command will return the active Remote mode. This is the Remote parameter that is seen on the front panel. Details of each mode are described in the local front panel operation section 5.4 REMOTE Parameters.

Example: COM?<cr>
Response: "1"<cr><lf>
0 = NONE (Local Control)
1 = ENABLE DB37
2 = ALL DB37
3 = RS232(COM:1 to enter RS232 ACTIVE mode)
6 = RS232 ACTIVE

***TST?**

The *TST? command will return the active fault number. The unit will respond with "HELP" followed by the fault number as shown below. If no faults are active the unit will respond with "OK". A list of possible faults is described in the <HELP> command above.

Example: *TST?<cr>
Response: "HELP 11"<cr><lf>

Example: *TST?
Response: "OK" <cr><lf>

BEAM?:

The BEAM? command will return a "0" or "1" for the status of whether or not the beam has reached the required operating window. A value of "1" indicates the beam is good. The criteria for beam good are the following:

- Discharge Voltage within +/- 10V of setpoint
- Discharge Current within +/- 0.51A of setpoint
- Emission Current within 75% of setpoint.

Note: emission current is always good if greater than the setpoint.

*When in Manual Control, Discharge Only, Keeper Only, or Emission Only modes <BEAM?> is always "1".

Example: BEAM?<cr>
Response: "1"<cr><lf>

DIS?:

The DIS? command will return a "0" or "1" for the status of whether or not the discharge has reached the required operating point. A value of "1" means the discharge is good. The criteria for discharge good are the following:

- Discharge Voltage within +/- 10V of setpoint
- Discharge Current within +/- 0.51A of setpoint

*When in Manual Control, Discharge Only, Keeper Only, or Emission Only modes <DIS?> is always "1".

Example: DIS?<cr>
Response: "1"<cr><lf>

EEI?:

The EEI? command will return a “0” or “1” for the status of whether or not the emission current has reached the required operating point. A value of “1” means the emission is good. The criteria for emission good are the following:

- Emission current within 75% of setpoint.

Note: emission current is always good if greater than the setpoint.

*When in Manual Control, Discharge Only, Keeper Only, or Emission Only modes EEI? is always “1”.

Example: EEI?<cr>
Response: “1”<cr><lf>

OUT:

The OUT: command is used to enable and disable the output. It accepts parameters of “0” or “1”. It responds with “OK”.

- 0 = Unit in standby, output disabled
- 1 = Output enabled

Example: OUT:<1>
Response: “OK”

OUT?:

The OUT? command is used to query the status of the output. It responds with “0” or “1”

- 0 = Unit in standby, output disabled
- 1 = Output enabled

Example: OUT?<cr>
Response: “1”<cr><lf>

LINEV:

The LINEV command is used to query the AC line voltage to the unit. It is reported in volts and is also available via the front panel Status page.

Example: LINEV<cr>
Response: “208”<cr><lf>

BUSV:

The BUSV command is used to query the main bus voltage within the unit. It is reported in volts and is also available via the front panel Status page.

Example: BUSV<cr>

Response: "400"<cr><lf>

TEMP1:

The TEMP1 command is used to query the temperature of one of the 3 temperature sensors within the unit. Temperature is reported in degrees C. This is also available via the front panel Status page.

Example: TEMP1<cr>

Response: "25"<cr><lf>

TEMP2:

The TEMP2 command is used to query the temperature of one of the 3 temperature sensors within the unit. Temperature is reported in degrees C. This is also available via the front panel Status page.

TEMP3:

The TEMP3 command is used to query the temperature of one of the 3 temperature sensors within the unit. Temperature is reported in degrees C. This is also available via the front panel Status page.

R: - Report:

The R: report command is used to query individual or all readbacks of all output parameters. The R: command takes a 3 digit parameter to specify which readback to return. The acceptable parameters are listed below.

Command Syntax: R:<parameter><cr>

Optional Parameters:

- <GS1> = Gas Channel 1 flow (sccm)
- <GS2> = Gas Channel 2 flow (sccm)
- <GS3> = Gas Channel 3 flow (sccm)
- <GS4> = Gas Channel 4 flow (sccm)
- <DSV> = Discharge Voltage (volts)
- <DSI> = Discharge Current (amps)
- <EEI> = Emission Current (amps)
- <EEV> = Emission Voltage (volts)
- <KPI> = Keeper Heating Current (amps)
- <KPV> = Keeper Voltage (amps)
- <ALL> = Returns all parameters listed above as a comma separated list GS1,GS2,GS3,GS4,DSV,DSI,EEI,EEV,KPI,KPV

Example: R:DSV<cr>
Response: "150"<cr><lf>

Example: R:ALL<cr>
Response: 50,0,0,0,150,5,6,42,1.5,32

P - Program Number:

The P command is used to set or query the active program number. It accepts one parameter which is a program number 1 – 4 or a ? to query.

Command Syntax: P<parameter>

Parameter = 1, 2, 3, or 4 to set the active program number. The ? parameter is used to query the active program number.

Set active program number = 1
Example: P1<cr>
Response: "OK"<cr><lf>

Query the active program number
Example: P?<cr>
Response: "1"<cr><lf>

P: - Program Values Set:

The P: program command is used to set program/setpoint values for all operating parameters. The P: command requires a program number parameter and an operating parameter. The acceptable parameters are listed below.

Command Syntax: P<program number>:<operating parameter><space>(value)

Program numbers 1 – 4 are accepted.

Optional Parameters:

- <GS1> = Gas Channel 1 flow (sccm)
- <GS2> = Gas Channel 2 flow (sccm)
- <GS3> = Gas Channel 3 flow (sccm)
- <GS4> = Gas Channel 4 flow (sccm)
- <DSV> = Discharge Voltage (volts)
- <DSI> = Discharge Current (amps)
- <EEI> = Emission Current (amps)
- <EEV> = Emission Voltage (volts)
- <KPI> = Keeper Current (amps)
- <ALL> = Set all parameters listed above as a comma separated list. (GS1),(GS2),(GS3),(GS4),(DSV),(DSI),(EEI),(EEV),(KPI)

Example: P1:DSV 150<cr>
Response "OK"<cr><lf>

Example: P1:ALL 50,0,0,0,150,5,5,50,1.5<cr>
Response: "OK"<cr><lf>

Px:? – Program Query:

The Px:? command is used to query the program/setpoint values of all pa-rameters individually or all at once. The P:? command also takes a <program> value and a <parameter> value the same as the Px: command.

Note: x = Program number

Acceptable program numbers are 0 – 4. The added program 0 value is for querying the current setpoint being used. This is useful if using full analog control to query the current setpoint being used by the unit since there are no program values. Program 0 only accepts the <ALL> parameter. It does not accept the individual queries. Program values 1 – 4 accepts <individual> and the <ALL> parameters

Command Syntax: P<program number>:<parameter>?<cr>

Example: P1:DSV? <cr>
Response: "150"<cr><lf>

Example: P0:ALL?<cr>
Response: "50,0,0,0,150,5,6,50,1.5"

This Page is Intentionally Blank

TROUBLESHOOTING

7-1

7. TROUBLESHOOTING

The following sections provide possible solutions to common problems as well as definition of all fault codes.

7.1 Basic Troubleshooting Table

The following table provides basic troubleshooting for possible problems that do not generate a HELP or Error code. For help with ERROR/HELP codes see Table 11: ERROR/HELP Fault Code Definitions below.

Table 7-1. Basic Troubleshooting

Description	Possible Cause
Unit will not save front panel setpoints when Program Load/Save button is pressed	<ul style="list-style-type: none"> •Front Panel cursor must be moved to the Program # location before program can be saved. •Press Item Select button after making changes to advance to the Program # field before pressing Program Load/Save. •See section Front Panel User Interface – Basic Operation for more details.
Front Panel cursor will not go to the Control, Remote, or Display locations.	<ul style="list-style-type: none"> •To access these locations the Item Select button must be pressed and held while turning the Adjust knob counter-clockwise. See section Front Panel User Interface – Basic Operation for more details.
Output will not enable from front panel when Output Enable button is pressed.	<ul style="list-style-type: none"> •Verify front panel Display mode = MAIN, DISCHARGE, KEEPER, or EMISSION. No other screens allow the output to be enabled. •Also verify the front panel cursor is not on the Display mode value. Press ITEM SELECT to advance the cursor.
Unit is not responsive to rear DB-37 KRI® Analog port pins.	<ul style="list-style-type: none"> •Verify unit is in REMOTE Mode ENABLE DB37 or DB37 ALL on the front panel.

Description	Possible Cause
Unit does not respond to setpoint changes to the rear DB-37 KRI® analog port, but responds to enable pin.	•Verify unit is in REMOTE mode “DB37 ALL” on the front panel.
Front Panel cursor skips over Gas set-points which are listed as OFF	•Gas channels must first be enabled and a maximum setpoint established from the front panel SETUP TWO - SET UNIT MAXIMUMS screen. This can be accessed as described in front control section Front Panel User Interface – Basic Operation.
Front Panel does not come on when AC power switch is turned on.	•Verify AC input voltage going into the unit meets the required AC input voltage spec. •If the AC input voltage is correct, contact KRI to return unit for repair.
Analog port setpoint and readback 0 - 5 V scaling is not correct to unit ratings.	•Verify unit maximums have not been decreased in the SETUP TWO - SET UNIT MAXIMUMS front panel screen. •See note at the bottom of the DB-37 analog port tables further describing this.

7.2 ERROR/HELP Codes

The following table defines all ERROR/HELP fault codes and provides possible causes.

Table 7-2. ERROR/HELP Fault Code Definitions

ERROR/HELP Code	Description	Possible Cause
2	Thermal Fault	•Broken Thermistor.
3	HC Start Fault	Hollow Cathode could not light. •Check supply connections and MFC connections.
4	Low Line Voltage	AC input voltage is too low. •Check AC input voltage.

TROUBLESHOOTING

7-3

ERROR/ HELP Code	Description	Possible Cause
5	Low Bus Voltage	Main DC Bus is too low. • Check AC input voltage and verify max total output power discharge + Keeper + Emission is not > 2500W.
10	Start Fault	The controller failed to ignite the ion source plasma. • Failed operating or in-vacuum cable from the eH-HC controller to the ion source. • Ion source anode has been coated with insulating material and needs to be cleaned. • Initial gas setpoints may be too high or low. Try decreasing or increasing flow. • Setpoint conditions are outside source operational area and are not sustainable. • Chamber pump speeds are too low limiting the operational range of the source.
11	Run Fault	Ion source plasma went out after ignition. Beam good criteria are not being met for a substantial time. • Gas flow is too low. • Operating cable or in-vacuum between eH-HC Controller and source failed. • Setpoint conditions are outside source operational area and are not sustainable. • Chamber pump speeds are too low limiting the operational range of the source.
12	Gas Fault	Gas flow readback is zero. • Gas supply is empty. • Gas shutoff is closed. • MFC failed. • MFC control cable failed. • MFC control cable connected to the incorrect port on the eH-HC controller.
13	Comm Link Down	Internal communication between the front panel and the main unit has been lost. • Contact KRI for repair.

ERROR/ HELP Code	Description	Possible Cause
16	Gat Drive Voltage Fault	Gate drive voltage is too low. •Something has likely failed internally in the eHF controller. Send unit back to KRI® for repair.
17	Interlock Fault	Interlock circuit is open. •Verify pins on the 2-pin Molex connector at the rear of the unit are connected.
18	Over Temperature Fault	Internal temperatures have exceeded limits. • Verify ambient temperature does not exceed 40° C. • Verify there are no obstructions blocking the air vents on the rear panel of the unit. • Leave AC power on to the unit with the output disabled and allow the fans to cool the unit. • If the unit continues to fault after being allowed to cool then KRI® should be contacted for repair.
19	Invalid RS-232 Command	RS-232 command was not recognized by the unit.
20	Needs to be in RS-232 Remote and Standby	RS-232 Error response. •If sending setpoint or enable commands to the unit, you must first put the unit in standby, then put it into RS-232 control.
21	Wrong Data Format	RS-232 Error response. •Verify command syntax is correct.
22	Data Too Large	RS-232 Error response. Data being sent to the RS-232 port has exceeded the buffer length. • Verify that carriage returns are being sent as terminators for each RS-232 command as described in the RS-232 command overview.
32	HC Run Fault	Hollow Cathode failed to stay running. •Check gas setpoints to ensure proper running conditions.
33	Readback Fault	485 Communication has failed between the secondary and main boards within the unit. • Contact KRI for repair.

TROUBLESHOOTING

7-5

ERROR/ HELP Code	Description	Possible Cause
34	GAS IO Not Ready Fault	Internal power and/or gas communication has been lost to the secondary board. • Contact KRI for repair.
64-70	P:ALL incorrect parameter position	RS-232 response to P:ALL command. Numbers 64 - 70 represent and index of 1 - 7 for the parameter that is incorrect in the command values. Command syntax = P:ALL GS1,GS2,GS3,GS4,DSV,DSI,EEI A problem with DSV would report an error value of 68.
99	Value Larger than Max Setting	RS-232 Error response. Value being sent exceeds the max value. • Verify value being sent in command does not exceed max value set for the unit. • Note: max values can be changed in the SETUP 2 menu via the front panel.
102	Discharge Current Latch	Discharge supply has detected excessive primary current. • Contact KRI® for repair.
103	Keeper Current Latch	Keeper supply has detected excessive primary current. • Contact KRI® for repair.
103	Emission Current Latch	Emission supply has detected excessive primary current. • Contact KRI® for repair.
112	Secondary In Boot	The Secondary control board is in “boot loader” mode. •Power cycle the unit. If this does not remedy the issue, contact KRI® for repair.

This Page is Intentionally Blank

8. MAINTENANCE

The only maintenance required is basic cleaning of the outside of the unit and rear air vents.



WARNING:

Hazardous voltages exist at the output. To prevent electric shock, unplug the unit before cleaning. Clean the outside of the instrument with a soft, lint-free, slightly damp cloth. Do not use detergent. Disassembly is not required or recommended for cleaning.

This Page is Intentionally Blank

WARRANTY

9-1

9. WARRANTY

Seller warrants to the Buyer that new Products will be free of defects in material and workmanship and shall conform to applicable specifications for a period of two(2) years from date of shipment. Seller does not warrant uninterrupted or error-free operation of the firmware. Seller's obligation under these warranties is limited to repairing or replacing, at Seller's option, defective Products. These services will be performed, at Seller's option, at either Seller's facility or Buyer's business location. For repairs performed at Seller's facility, Buyer must contact Seller in advance for authorization to return Products and must follow Seller's shipping instructions. Freight charges and shipments to Seller are Buyer's responsibility. Seller will return the Products to Buyer at Seller's expense. All parts used in making warranty repairs will be new or of equal functional quality. Seller assumes no liability under the above warranties and the following are specifically excluded from all warranties including Product defects resulting from (1) abuse, misuse, or mishandling; (2) damage due to forces external to the Product including, but not limited to, Force Majeure, power surges, power failures, defective electrical work, foreign equipment/attachments, or utilities, gas or services; (3) the use of parts not supplied by the Seller; (4) improper operation or maintenance, servicing, installation or (5) failure to perform preventive maintenance in accordance with Seller's recommendations (including keeping an accurate log of preventive maintenance). In addition, this warranty does not apply if any Products have been modified without the written permission of Seller or if any Seller serial number has been removed or defaced. THIS WARRANTY IS GIVEN IN LIEU OF ALL OTHER WARRANTIES, EXPRESS OR IMPLIED, INCLUDING IMPLIED WARRANTIES OF MERCHANTABILITY, TITLE, NON-INFRINGEMENT, FITNESS FOR A PARTICULAR PURPOSE OR USE, OR OTHERWISE. IN NO EVENT SHALL SELLER'S TOTAL LIABILITY TO BUYER EXCEED THE PURCHASE PRICE OF THE PRODUCTS.