

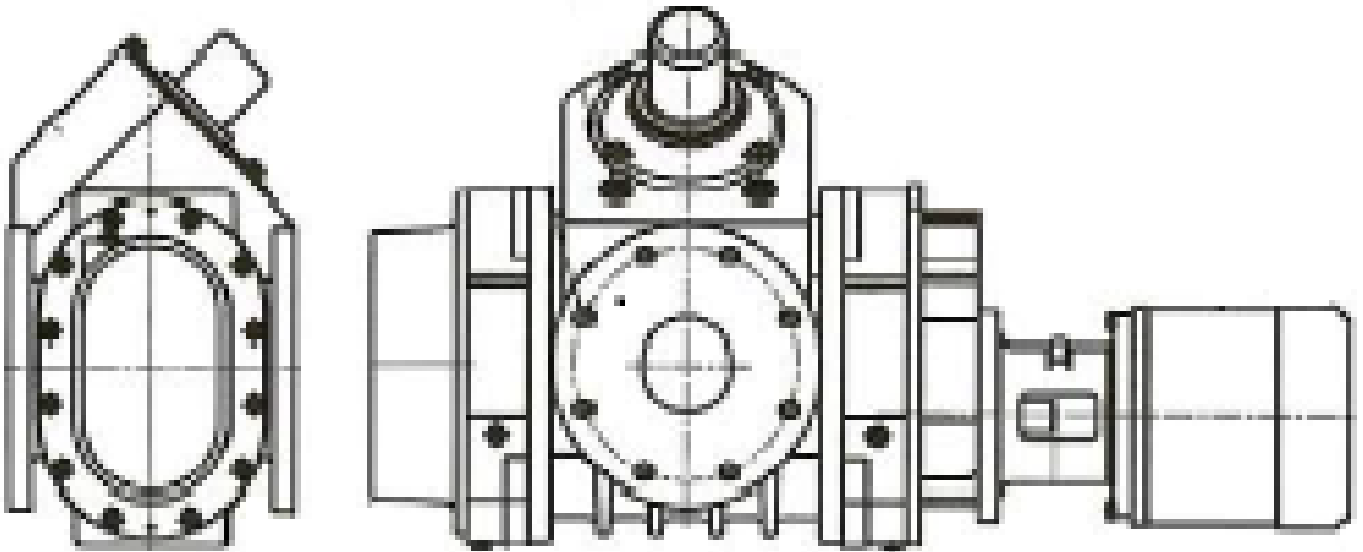

**Uni-Vac 300 Series  
User Manual**



**Trillium US, Inc.  
3627 State Route 23 South  
Hamburg, NJ 07419**

**Tel: 973.827.1661      Fax: 973.827.8883**

**[www.trilliumus.com](http://www.trilliumus.com)**

### Model:300 Series

OIL CAPACITY : 1 1/2 PINTS(0.8 LITER)  
 APPROX. WEIGHT : 286 LBS(130KG)

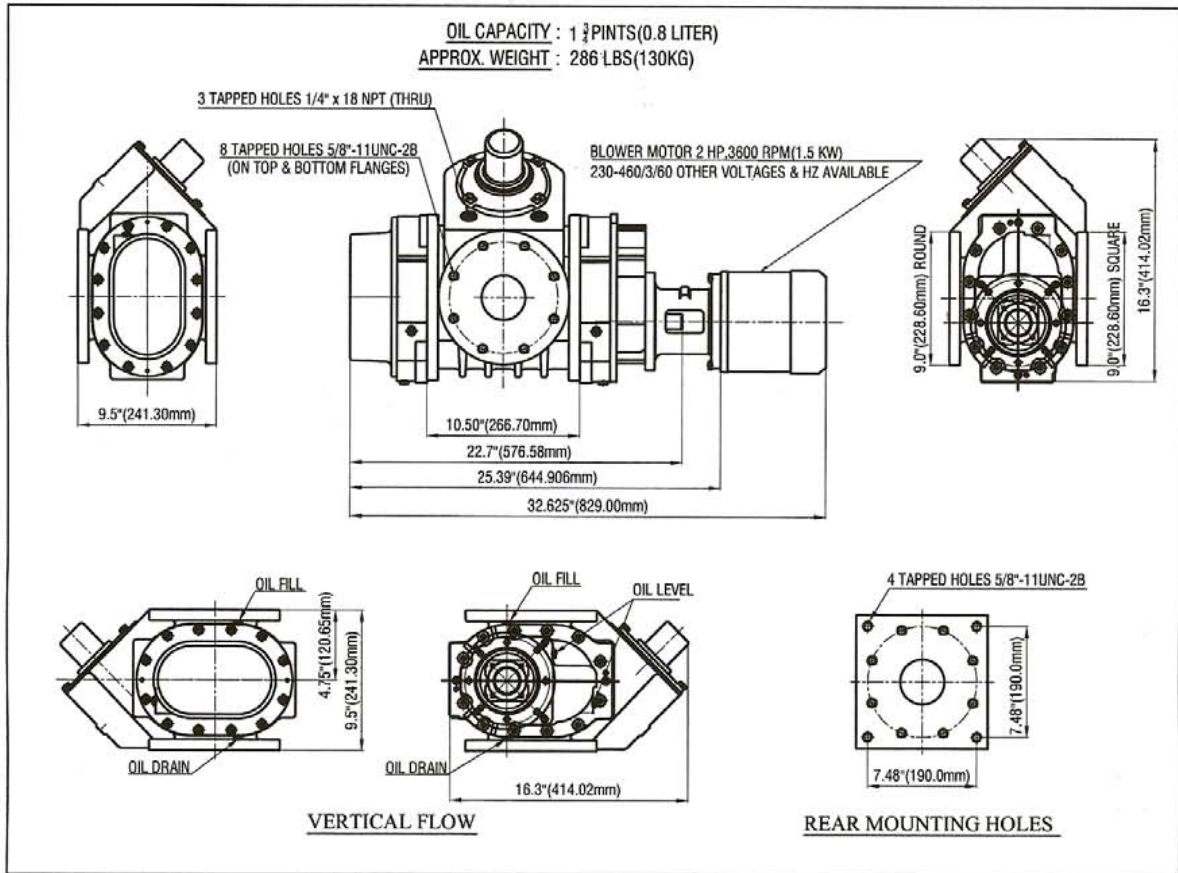

| 310 BPV Specification  |   |
|------------------------|---|
| Free Air Displacement: | 680m <sup>3</sup> /hr(400 CFM),3600 RPM@60 Hz |
| Motor:                 | 2 HP 208 / 230 / 460V                         |
| Inlet and Outlet :     | 4" ASA  |
| Weight :               | 130 Kg.(Aprox.)                               |

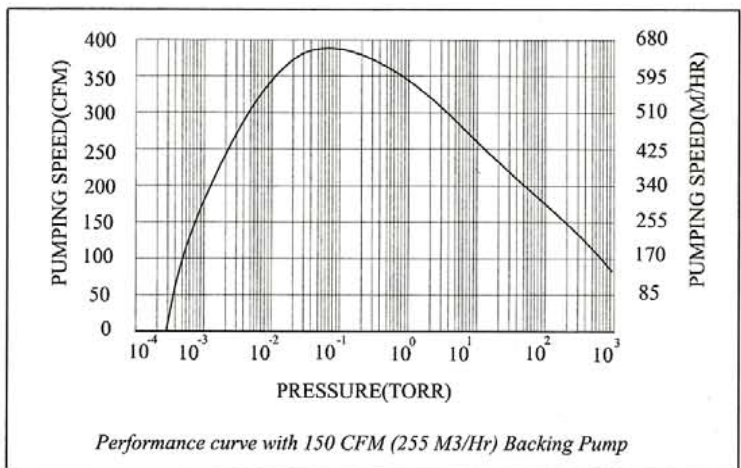

Note: For operation at 50 Hz Pump speed is 5/6 (0.833) of that shown.

## TABLE OF CONTENTS

| Section   | Description  | Page  |
|-----------|--|-------|
|           | TABLE OF CONTENTS  | 2     |
|           | NOTE   | 3     |
|           | WARNING  | 4     |
|           | SAFETY PRECAUTIONS   | 5     |
|           | CAUTION  | 6     |
| <b>1.</b> | <b>DESCRIPTION</b>   |       |
|           | 1.1 Principle of Operation                                   | 7     |
|           | 1.2 Maximum Allowable Operating Conditions                   | 8     |
|           | 1.3 Lubricant  | 8     |
| <b>2.</b> | <b>INSTALLATION</b>  |       |
|           | 2.1 General  | 9     |
|           | 2.2 Belt Drive   | 10    |
|           | 2.3 Direct Drive   | 10    |
|           | 2.4 Oxygen service   | 11    |
|           | 2.5 Cleaning   | 11    |
|           | 2.6 Lubrication  | 11    |
|           | 2.7 Lubrication Schedule                                     | 12    |
|           | 2.8 Lubrication Diagrams- Vertical Flow                      | 13    |
|           | 2.9 Lubrication Diagrams- Horizontal Flow                    | 14    |
| <b>3.</b> | <b>OPERATION</b>   |       |
|           | 3.1 Instruction  | 15    |
| <b>4.</b> | <b>General</b>   |       |
|           | 4.1 Note   | 16    |
|           | 4.2 Drive Shaft Seal Maintenance                             | 17    |
|           | 4.3 Oil Seal Removal   | 17    |
|           | 4.4 Installation of new Seal – old style casting             | 18    |
|           | 4.5 Installation of new Seal – New style casting             | 20    |
|           | 4.6 Painting   | 21    |
|           | 4.7 Seal insertion tool                                      | 21    |
|           | 4.8 Seal parts kits – Direct drive blower/ Belt drive blower | 21-23 |
|           | 5.0 Oxygen service   | 24    |
| <b>5.</b> | <b>EXPLANATION OF THE 300 SERIES BLOWERS</b>                 | 25    |
| <b>6.</b> | <b>300 SERIES PART LIST</b>                                  | 26-28 |

**NOTE**



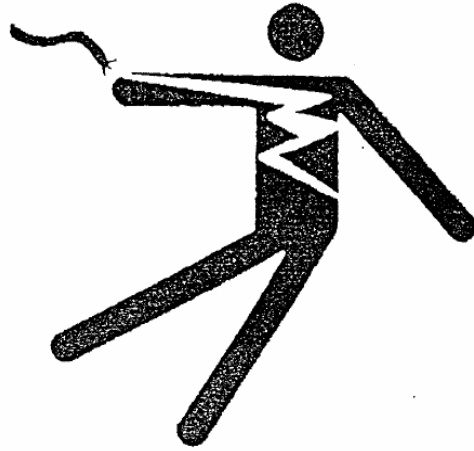

**THE INFORMATION HEREIN SHALL BE  
TREATED IN STRICT CONFIDENCE, AND  
SHALL NOT BE DISCLOSED TO A THIRD  
PARTY WITH OUT PRIOR PERMISSION OF  
TRILLIUM US, INC.**

**THIS INFORMATION SHALL BE USED  
SOLELY FOR THE PURPOSE WHICH IT  
HAS BEEN SUPPLIED AND FOR NO OTHER  
PURPOSE WHATSOEVER**

## WARNING



**Hazardous voltage.  
Can shock, burn, or cause death.**

-  **Disconnect power before working on pump or motor.**
-  **Ground motor before connecting to electrical power supply.**
-  **Failure to ground motor can cause severe or fatal electrical shock hazard.**
-  **Supply voltage must be within  $\pm 10\%$  of nameplate voltage. Incorrect voltage can cause fire or seriously damage motor and voids warranty. If in doubt consult United Vacuum, Inc.**

## **SAFETY PRECAUTIONS**

For equipment covered specifically or indirectly in this instruction book, it is important that all personnel observe safety precautions to minimize the chances of injury. Among many considerations, the following should particularly be noted.

1. Pump casing and associated piping or accessories may, even under normal operating conditions, become hot enough to cause major skin burns on contact.
2. Internal and external rotating parts of the booster and driving equipment can produce serious physical injuries. Do not reach into any opening in the booster while it is operating, or while subject to accidental starting. Cover external moving parts with adequate guards.
3. Disconnect power before doing any work, and avoid by-passing or rendering inoperative any safety or protective devices.
4. Stay clear of open inlet piping (suction area) and the open discharge.
5. Stay clear of the blast from pressure relief valves and the suction area of vacuum relief valves.
6. Use proper care and good procedure and handling, lifting, installing, operating and maintaining the equipment.
7. Casing pressure must not exceed 25 psi. Do not pressurize vented cavities from and external source, nor restrict the vents.
8. When adding to or drawing oil from or otherwise servicing a blower which has been pumping toxic, flammable, explosive or other hazardous substances, observe appropriate precautions to avoid serious personal injury.

## **CAUTION**

**VACUUM BOOSTER IS SHIPPED  
WITH OIL IN SEPARATE  
CONTAINER.**

**BEFORE OPERATING, FILL THE  
REQUIRED AMOUNT OF OIL INTO  
THE THREE OIL RESERVOIRS AS  
PER INSTRUCTIONS UNDER  
LUBRICATION.**

**DO NOT FILL OIL RESERVOIRS  
UNTIL VACUUM BOOSTER IS  
MOUNTED IN ITS OPERATING  
LOCATION.**

### 1.1. Principle of operation

United Vacuum Model: 300 Series blowers are a single stage positive displacement vacuum booster machines. The blower consists of two double lobe impellers that are mounted in parallel, and rotate in synchronous mesh in a one-piece cylinder. As gas enters the inlet port it fills a cavity exposed by rotation of the impellers, Fig. 1, position 1. The impellers continue to turn and trap a quantity of gas between the rotating impeller and blower casing, Fig. 1, position 2. Further rotation pushes the trapped volume around the cylinder through the discharge port, Fig. 1, position 3.

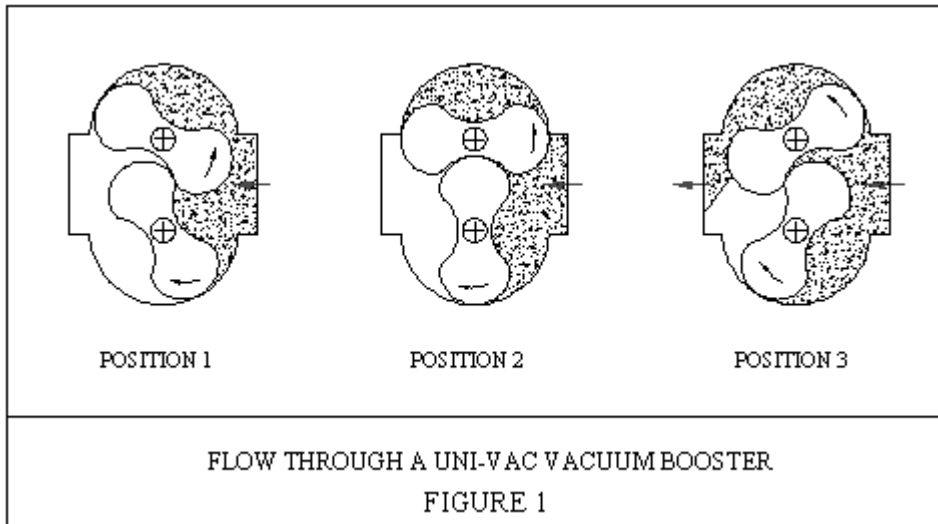

The high vacuum blowers covered in this manual are intended especially for use as a preceding stage of a vacuum pumping system with a suitable pump or roughing pump that will allow the blower to operate satisfactorily within its pressure and temperature limits. They are not intended for duty as positive pressure blower.

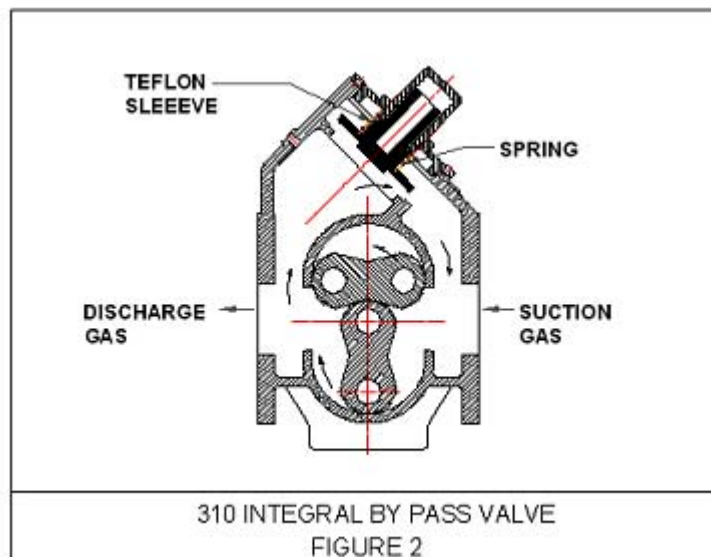

The bypass blower is intended to minimize pump down times and depending on the capacity of the backing pump may not be suitable for continuous operation in the pressure range where the bypass is open. Consult the factory for special applications.

#### 1.1.1 CFM Capacity



300 Series @3600 RPM = 400 CFM

## 1.2. MAXIMUM ALLOWABLE OPERATING CONDITIONS

| PARAMETERS            |                         | 300 SERIES |
|-----------------------|-------------------------|------------|
| SPEED (RPM)           |                         | 3600       |
| PRESSURE RISE         | 400 TORR                |            |
| TEMPERATURE RISE      | 275 DEG. F (135 DEG. C) |            |
| DISCHARGE TEMPERATURE | 375 DEG. F (191 DEG.C)  |            |
| DRIVE H.P             | 5 H.P (MAX.)            |            |

Note: Maximum pressure rise, temperature rise and horsepower do not necessarily coincide. Whichever limit reached first, is to be considered as the limiting factor.

## 1.3. LUBRICANT

Lubricating oil is shipped in a separate container. Refer to section 2.6 thru 2.9 for proper amount and filling procedure.

## 1.4 BOOSTER ARRANGEMENTS

Vacuum boosters are available (factory arranged) for belt or direct drive and for vertical or horizontal.

## 1.5 SAFETY PRECAUTIONS

For equipment covered specifically or indirectly in this instruction book, it is important that all personnel observe safety precautions to minimize the chances of injury. Among many considerations, the following should particularly be noted.

1.5.1 Pump casing and associated piping or accessories may, even under normal operating conditions, become hot enough to cause major skin burns on contact.

1.5.2 Internal and external rotating parts of the booster and driving equipment can produce serious physical injuries. Do not reach into any opening in the booster while it is operating, or while subject to accidental starting. Cover external moving parts with adequate guards.

- 1.5.3 Disconnect power before doing any work, and avoid by-passing or rendering inoperative any safety or protective devices.
- 1.5.4 Stay clear of open inlet piping (suction area) and the open discharge.
- 1.5.5 Stay clear of the blast from pressure relief valves and the suction area of vacuum relief valves.
- 1.5.6 Use proper care and good procedure and handling, lifting, installing, operating and maintaining the equipment.
- 1.5.7 Casing pressure must not exceed 25 psi(172kpa) gauge. Do not pressurize vented cavities from an external source, nor restrict the vents.
- 1.5.9 When adding to or drawing oil from or otherwise servicing a blower which has been pumping toxic, flammable, explosive or other hazardous substances, observe appropriate precautions to avoid serious personal injury.

## **2. INSTALLATION**

### **2.1. General**

On receipt of the unit, check for any damage that may have occurred during transit. Report any damage or missing parts as soon as possible.

- 2.1.1. During installation, protective coverings should be left in place to reduce the chances of intrusion of foreign material and rusting. Protection against chemical or salt water atmosphere is not provided. The interior is protected against normal atmospheric corrosion by small bags of an absorbent material fastened to the flange covers.
- 2.1.2. Before operating, put the required amount of oil into the three oil reservoirs as per instructions under lubrication.
- 2.1.3. The vacuum booster should be mounted on a smooth, flat, level surface. The degree of variation in level should not exceed 1/16" per horizontal foot (1.588 mm per horizontal 30.48 cm) in any direction.
- 2.1.4. Before starting, turn drive shaft over manually counter – clockwise only to ensure that no foreign material is present in the impeller cavity.
- 2.1.5. Inlet and outlet piping should have a proper flexible coupling in the line.
- 2.1.6. It is important to maintain all pipes and fittings free of debris. If this requirement is not adhered to, jamming and internal damage to the vacuum booster may occur. A Uni-Vac inlet vacuum filter is recommended to provide protection for the booster.
- 2.1.7. Rotation is counter clockwise only facing the shaft.

### **2.2 BELT DRIVE**

- 2.2.1. The sheave should be located as close as practical to the booster or back belt guard and should not overhang the shaft. The motor sheave must be in alignment with the booster sheave and belts tightened according to V-belt manufacturer instructions.

**MINIMUM RECOMMENDED SHEAVE (PULLEY) P.D. FOR VACUUM BOOSTER IS 4.2" (106.68MM)**

**2.3 DIRECT DRIVE**

2.3.1 The Uni-Vac direct drive attachment consists of a resilient cushion type flexible coupling Fig. (3), motor adaptor with cover, oil seals and flange mounted motor. The coupling does not require lubrication. If the Uni-Vac direct attachment is not used, follow section 2.3.2 and the selected coupling manufacturer's instruction for shaft alignment.

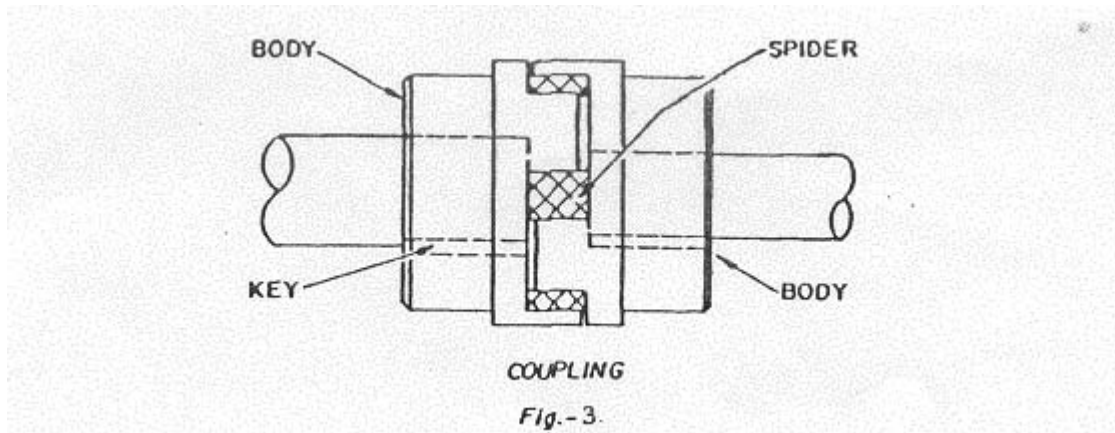

2.3.2 Misalignment can be either parallel or angular. Maximum allowable deviation in offset is : 0.002" ( 0.0508mm) total indicator reading. The two inside faces of the coupling should not vary more than 0.001" (0.0254mm) from parallel. See Fig. (4).

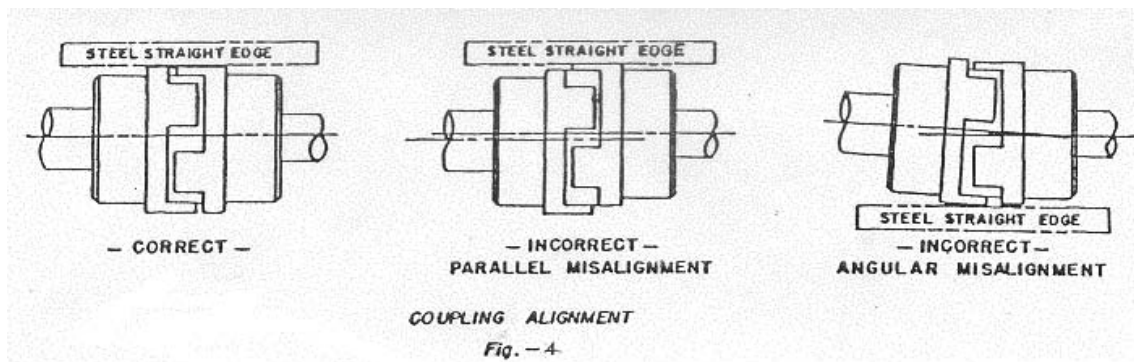

**2.4 OXYGEN SERVICE**

2.4.1 Vacuum booster intended for oxygen service receive special preparation for shipment.

2.4.2 Oxygen service booster requires special oils. We recommend either

fomblin Y25/5 or Krytox 1525.

**!! WARNING !!**

Substitutes cannot be used. Use of other oils or contamination with hydrocarbons can result in an explosion.

2.4.3 Clean vacuum piping lines (internally) and flanges three (3) times so that they are completely free of any foreign particles and allow the surfaces to air dry before assembly.

**2.5. CLEANING (Standard Vacuum Booster)**

2.5.1 A clean rag dampened with Loctite safety solvent or equivalent can be used to clean the booster impeller section and flanges if they have accumulated dirt during installation or storage.

**2.6. LUBRICATION (See Fig. 5 & 6)**

2.6.1 The vacuum booster has three oil reservoirs :

- (A) Lip seal reservoir
- (B) Bearing housing (drive end) reservoir
- (C) Gear housing reservoir

2.6.2 A) The lip seal oil reservoir is vented to atmospheric pressure. The volume of oil that fills the reservoir between the seals is used to lubricate the seal rubbing surface and prevent leakage of atmospheric air into the vacuum booster.

2.6.3 (B) The bearings in the bearing housing (drive end) reservoir are lubricated by splash from an oil slinger that dips into the oil sump.

2.6.4 (C) In the gear housing reservoir, the gears are lubricated by partial immersion in the oil sump. Splash from the gears and oil slinger lubricates both gear and bearings.

2.6.5 To fill bearing housing (drive end) and gear housing reservoirs, STOP UNIT AND BREAK VACUUM. LUBRICATING OIL MAY NOT BE ADDED WHILE VACUUM BOOSTER IS IN OPERATION.

2.6.6 Note that bearing housing (drive end) and gear housing reservoir may be under vacuum. The following table shows the normal oil capacities of the oil reservoirs. The oil may be added to the lip seal reservoir during operation.

2.6.7 Fill the three reservoirs with the recommended lubricant to the middle point of the sight glasses. Wait for a period of three minutes to allow oil level to equalize.

### 2.6.8 Appropriate “Uni-Vac 405” Oil Capacity in Fluid Oz. (Milliliters)

| Location                  | Ozs.       |          | Milliliters |          |
|---------------------------|------------|----------|-------------|----------|
|                           | Horizontal | Vertical | Horizontal  | Vertical |
| Seal Reservoir            | 7.75       | 7.5      | 229         | 220      |
| Drive End Bearing Housing | 3.75       | 7.75     | 111         | 230      |
| Gear Housing              | 8.25       | 12.5     | 244         | 370      |

**Note :**

Do not overfill or permit oil level to fall below the bottom of the sight glasses. When the blower is in operation, the oil level will drop in the gear housing reservoir due to the rotating action of the gears. This is normal and no cause for concern as long as oil levels are in the middle of the sight glass with the blower not running. All “fill & drain plugs” should be sealed. If the seal reservoir is over-filled, excess oil may flow from the vent hole in the filler plug when the oil is heated. No harm is done to the booster if this leakage occurs and the leakage will stop as soon as all excess oil has been expelled. If the drive end bearing or gear end reservoirs are over filled, oil may spill over into the blower body.

## 2.7 LUBRICATING SCHEDULE

Note : Frequency of oil changes depends upon the operating conditions.

2.7.1 Normal operating conditions, during the first week, the oil levels on each end of the vacuum booster should be checked at every 24 hours of operation. Bearing and gear oil should be changed at every 2000 operating hours. Oil in the seal reservoir does not require changing. Add oil to maintain proper level as necessary.

2.7.2 Note : Both Bearing oil reservoirs are to be filled with oil only when the blower is mounted in its operating location.

2.7.3 Under severe operating conditions such as contamination within the vacuum system or excessively high operating temperatures within the vacuum booster, more frequent oil changes are recommended.

## 2.8 LUBRICATION DIAGRAM–VERTICAL FLOW (MODEL: 300 SERIES)

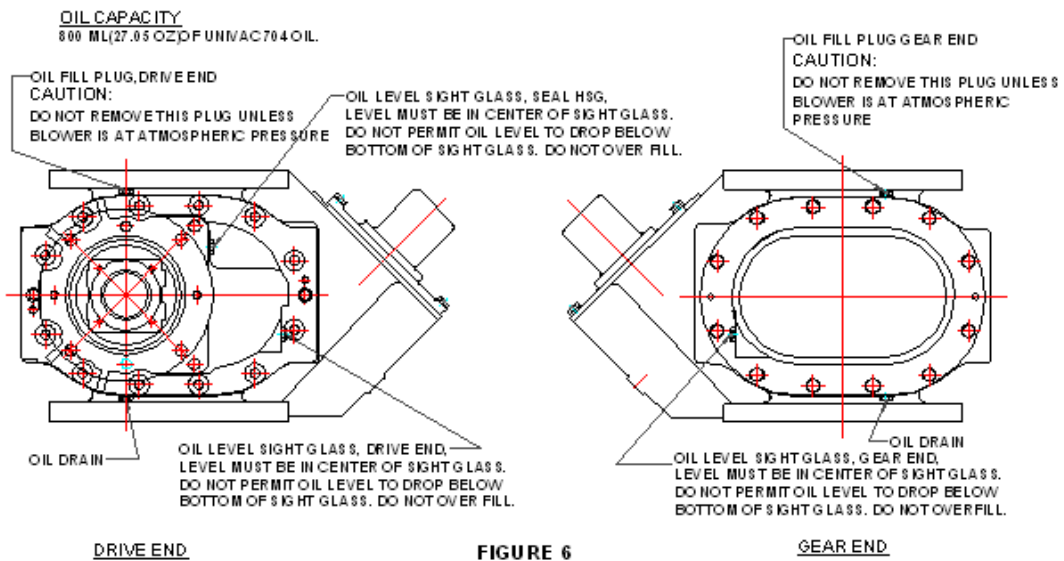
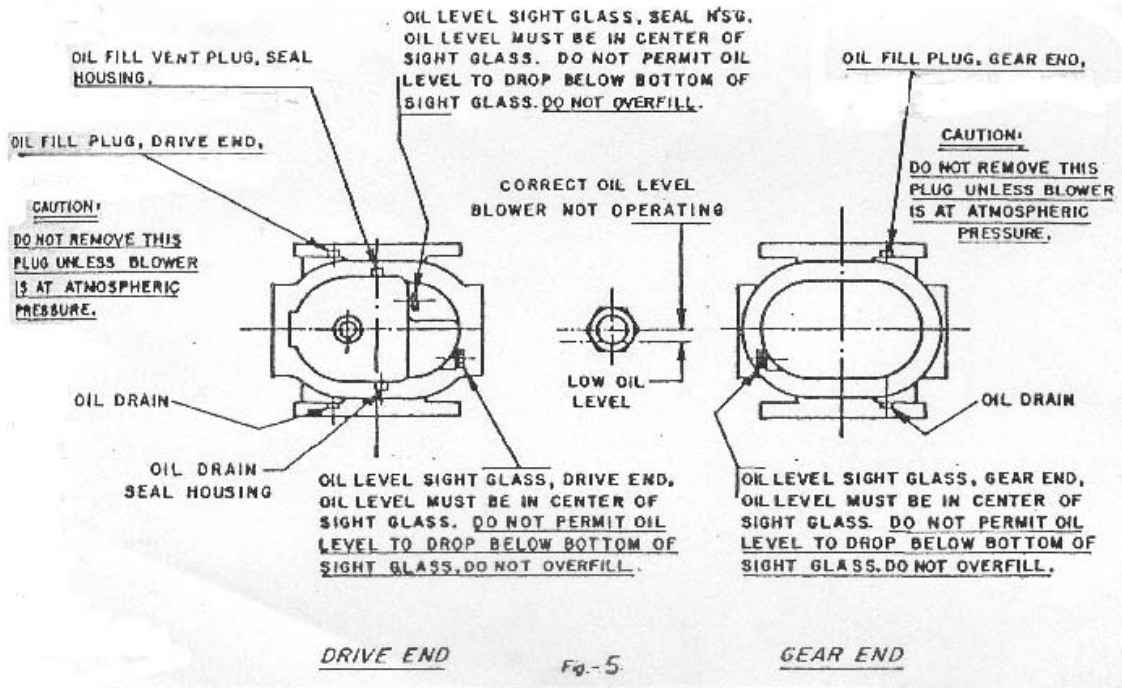

**NOTE :** (1) For standard applications use “Uni-Vac 405” oil as lubricant. Coat threaded plugs with Teflon paste sealant.

(2) There are three (3) oil reservoirs and three (3) oil fill-in plugs.



- (3) All oil fill plugs and oil drain plugs have straight threads with fluorocarbon brown “O” rings.
- (4) No threaded sealant is required on straight thread plugs. The “O” ring will do the sealing . Each time the fill or drain plugs are removed, the “O” rings must be inspected for cuts or damaged & replaced if necessary.
- (5) If your blower is equipped with taper pipe threaded, fill and drain plugs on the drive end and gear end and you have removed them for servicing, it is absolutely necessary, before reinstalling them, that they be cleaned of old thread sealant for the service. See note: 6 for the proper threaded sealants. No thread sealant is required on straight thread O-ring type plugs: but the O-ring should be inspected and replaced if damaged or no longer resilient.
- (6) For oxygen service, see 2.4.2, Page 8 for recommended oil. Coat threaded plugs with OXY-8 Paste Sealant.

## 2.9. LUBRICATION DIAGRAM- HORIZONTAL FLOW (MODEL: 300 SERIES)

See 2.6.8 for oil quantities

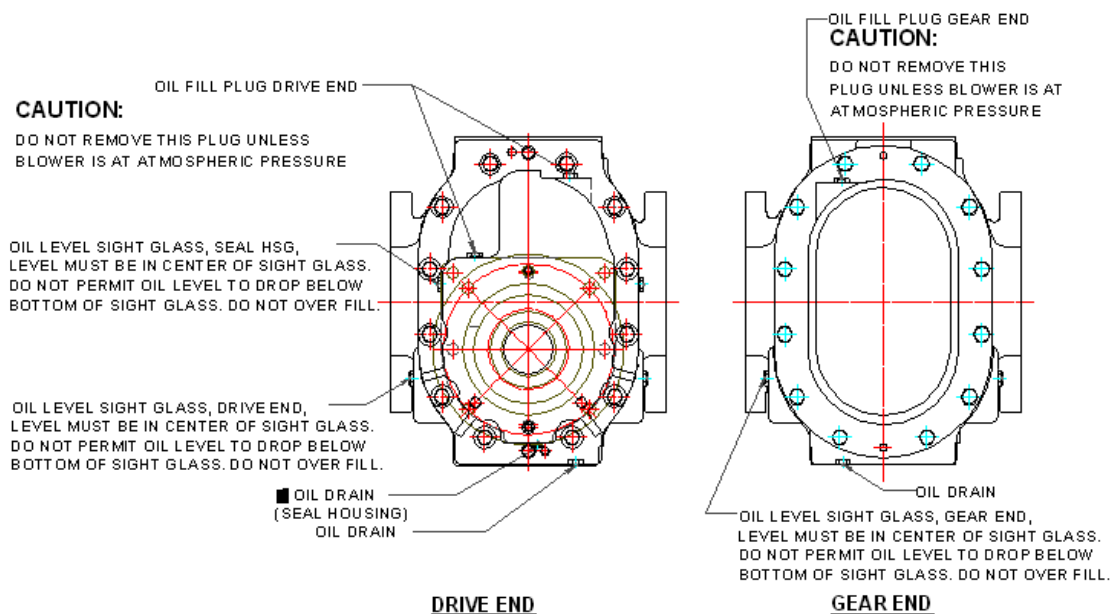

**FIGURE 7**

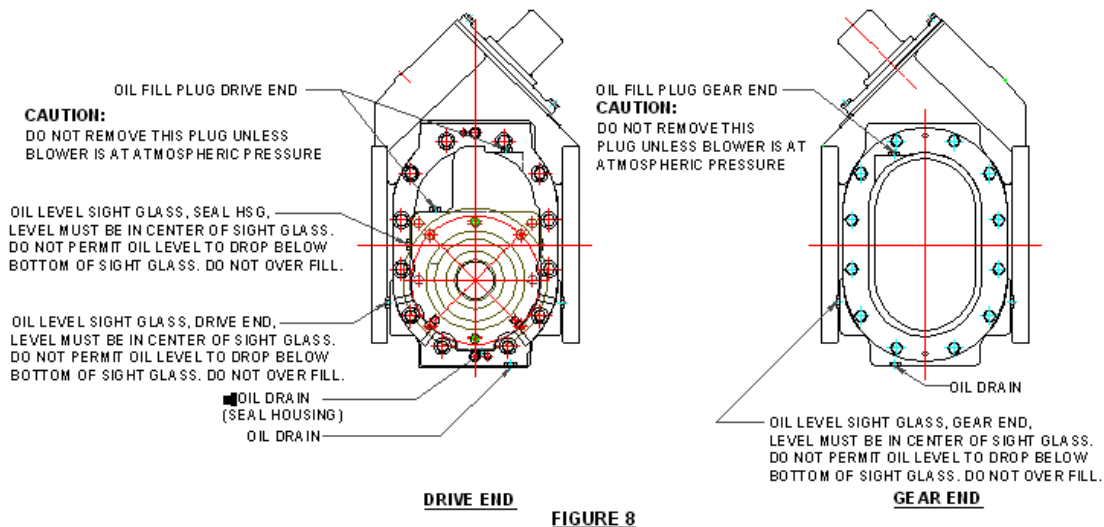

**Note:** (1) For standard applications use “UV 405” oil as lubricant. Coat threaded plugs with Teflon paste sealant.

- (2) There are oil reservoirs and three oil fill-in plugs.
- (3) All oil fill plugs and oil drain plugs have straight threads with fluorocarbon brown “O” rings.
- (4) No thread sealant is required on straight thread plugs. The “O” ring will do the sealing . Each time the fill or drain plugs are removed, the “O” rings must be inspected for cuts or damage.
- (5) If your blower is equipped with taper pipe threaded, fill and drain plugs on the drive end and gear end and you have removed them for servicing, it is absolutely necessary, before reinstalling them, that they be cleaned of old thread sealant . See note: 6 for the proper threaded sealants. No thread sealant is required on straight thread O-ring type plugs: but the O-ring should be inspected and replaced if damaged or no longer resilient.
- (6) For oxygen service, see 2.4.2, Page 8 for recommended oil. Coat threaded plugs with OXY-8 Paste Sealant.

### 3.0 OPERATION

#### 3.1. Instruction



Note : Do not attempt to operate the unit until checked as per the installation instructions.

- 3.1.1. If the unit rotates freely and direction of rotation is correct, the unit may be started. A preliminary run-in periods of five minutes at no-load should reveal any inherent problems. If required, corrections should be made immediately.
- 3.1.2. A one-hour run at blank-off should be made to check for loud noises, excessive, vibration, seal leakage in the vacuum booster.
- 3.1.3 After steps (1) and (2) have been completed, a run at normal pressure conditions for about fifteen minutes should be initiated. Observe the behaviour of the vacuum booster for excess noise and vibration.
- 3.1.4 During initial operation for the first week, observation of oil levels should be made on a daily basis to determine if any losses occur. Oil levels should not drop below the bottom of the sight glasses.
- 3.1.5 Periodically check drive belt tension and the booster for unusual noises and increase in vibration.

## **4.0 GENERAL**

### **4.1 Note:**

- 4.1.1 In general, major repairs are to be considered beyond the scope of maintenance work and should be performed at the factory, after arrangement through United Vacuum. Warranty failures should not be repaired at all, unless specific written authorization has been obtained through United Vacuum before starting the work. Unauthorized disassembly during the warranty period may void the warranty.
- 4.1.2 A consistent program of inspection and maintenance servicing is the most effective method of minimizing booster repairs or operating problems. A simple record of services and dates is recommended to help this work on a regular schedule.
- 4.1.3 Correct lubrication is probably the most important requirement, other than operating the booster within its specified rating limits. In a new and properly installed unit there are no moving contacts between the two impellers, or between the impellers and the body or bearing housings. Wear is confined to the timing gears, the bearing which support and locate the shafts and the drive shafts seals. All are lubricated and wear should be minimal if clean oil of the proper grade is used.
- 4.1.4 The bearing and gears supplied with the Uni-Vac boosters are generously sized and should give years of trouble-free service under normal operating conditions. The drive shaft seal should be considered as expendable and may be replaced in the field. Design of the booster is

basically simple, minor repair operations are straight forward, but the work should be done by personnel with good mechanical experience. No attempt is made in this manual to outline procedures for replacing bearings and gears or for timing the impellers. Best result will be obtained by having such repairs done by United Vacuum.

- 4.1.5 Design of the booster is basically simple, minor repair operations are straight forward, but the work should be done by personnel with good mechanical experience. No attempt is made in this manual to outline procedures for replacing bearings and gears or for timing the impellers. If this work is attempted, it will be necessary to rely on assembly drawings. Ref: Uni-Vac vacuum booster dwg. Ref: Exploded view & sectional view.

## **4.2 DRIVE SHAFT SEAL MAINTENANCE**

The drive shaft seal assembly consists of two individual pressure type seals submerged in oil and located in the seal housing. Two different types of seals are used and care must be taken to assure that the seals are not interchanged. Seals should be replaced as an assembly whenever oil leakage through the inboard seal becomes excessive as indicated by a rise in oil level in the drive end bearing reservoir. Leakage through the outboard seal is not likely to be excessive unless the seal or its shaft bearing surface is damaged. Shaft must be smooth and free from scratches.

## **4.3 OIL SEAL REMOVAL**

**Note: DRAIN ALL LUBRICANTS FROM THE SEAL HOUSING AND BEARING HOUSING DRIVE END RESERVOIRS.**

- 4.3.1 Seal housing assembly.
- 4.3.2 Belt drive – remove reservoir cover and gasket.
- 4.3.3 Direct drive - remove motor and its coupling half. Booster coupling hub is to be removed before the motor support and “O” rings are removed.
- 4.3.4 Remove all bolts securing seal housing to bearing housing. Using two of the seal housing attachment bolts, jack seal housing from bearing housing drive end.

4.3.5 Tighten jack bolts evenly to prevent dowel pins from binding. See Fig.9

**NOTE: CARE MUST BE TAKEN NOT TO SCORE THE SHAFT.**

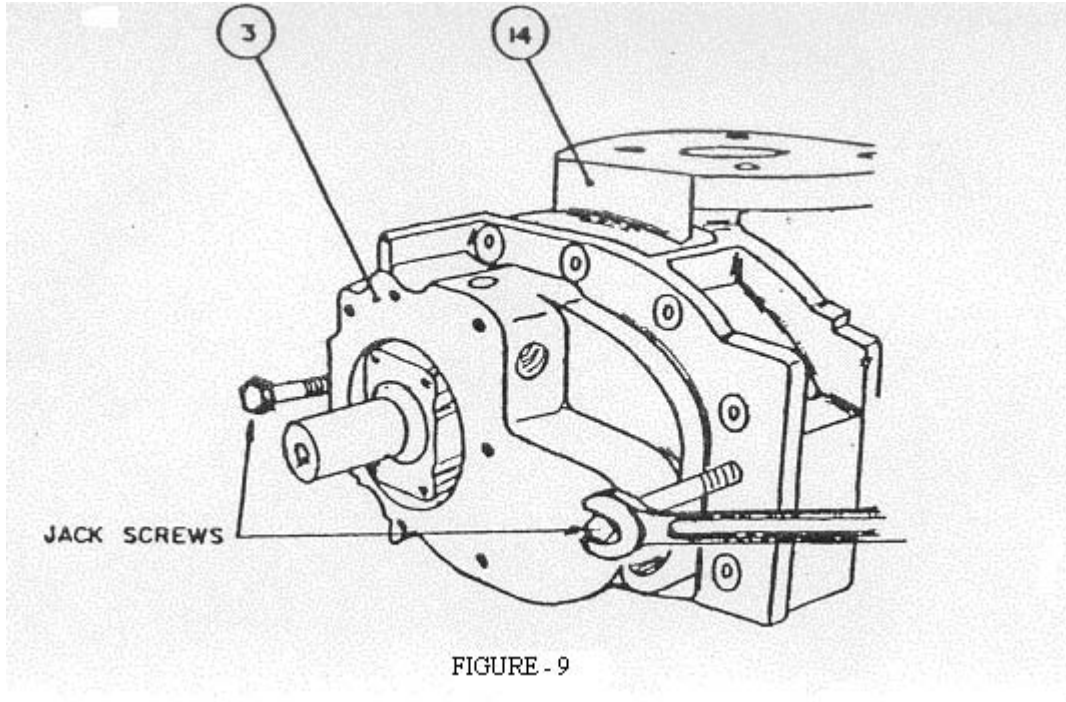

4.3.6 Removal of seals is accomplished by pressing both out through the seal bore. Seals removed from the seal housing and motor support bracket are not re-usable.

4.3.7 Pressing out of seals may be done from either side. Care must be exercised to prevent the pressing tool from scratching the seal bore. Carefully clean and inspect seal bore and clean out any dirt or debris from seal oil reservoir.

4.3.8 Scrape flange face of bearing housing and mating face of seal housing clean before assembling. Clean with gasket remover. All traces of old sealant must be removed.

### **Old Style Casting**

## **4.4 INSTALLATION OF NEW SEALS**

- 4.4.1 Carefully inspect new lip seals and “O” ring for cuts or nicks on the sealing lip and for any burrs on the outer metal rim. Discard seal if any lip defects are apparent.
- 4.4.2 Place new seal on pilot of press adapter tool (UV-429-606-002) with lip of seal facing out and metal case against tool shoulder, apply Loctite to ID of bore and OD of Seal assy. Apply Loctite to ID of bore and OD of seal. Seal insertion tool can be procured from United Vacuum.

4.4.3

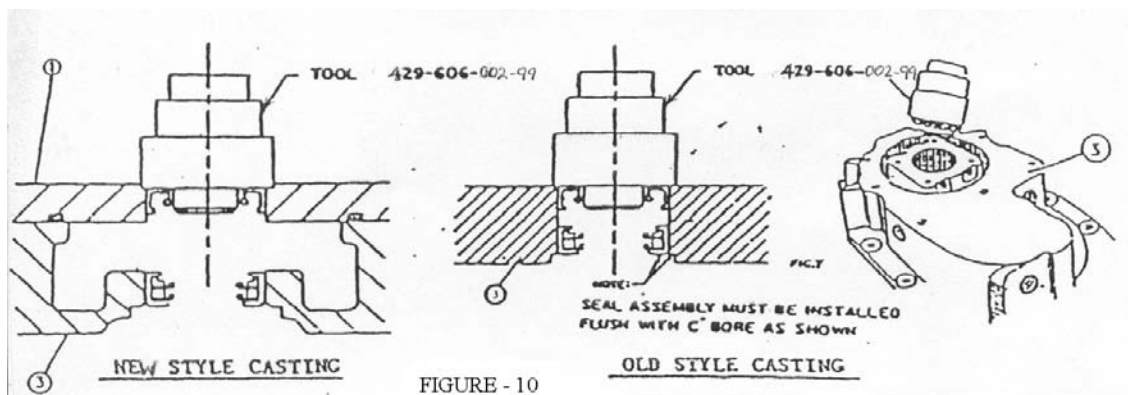

- 4.4.4 Press outer seal into bore or seal housing. Press tool until solid contact is made. This procedure is to insure that the seal is square in the bore.
- 4.4.5 Allow loctite to set-up for 5 to 10 minutes before removing tool. Install inner from opposite side using same procedure.
- 4.4.6 **!! CAUTION !! SEALS MUST BE LOCATED AND ORIENTED AS SHOWN IN UNI-VAC VACUUM BOOSTER DWG. (EXPLODED VIEW & SECTIONAL VIEW)**
- 4.4.7 Install “O” ring in sleeve, assemble sleeve on shaft. Sleeve must be tight against shoulder.
- 4.4.8 Clean housing faces and covers with gasket remover. Apply thin bead of sealant Loctite gasket eliminator between seal housing and bearing housing.

4.4.9 Apply tape over keyway slot. Slide seal housing over drive shaft, hold housing square with shaft to prevent damage to seals, engage dowel pins in bearing housing and tap seal housing firmly in place.

4.4.10 Secure seal housing to pump body flange with hex head cap screws. Torque all bolts to 13 ft. lbs.

### **New Style Casting**

#### **4.5 INSTALLATION OF NEW OIL SEALS**

4.5.1. Carefully inspect new lip seals and “O” ring for cuts or nicks on the sealing lip and for any burs on the outer metal rim. Discard seal if any lip defects are apparent.

4.5.2 Place new seal on pilot of press adapter tool (UV-429-606-002) with lip of seal facing out and metal case against tool shoulder, apply Loctite to ID of bore and OD of seal assy. Apply Loctite to ID of bore and OD of seal. Seal insertion tool can be procured from United Vacuum.

4.5.3 Press inner seal into bore or seal housing. Press tool until solid contact is made. This procedure is to insure that the seal is square in the bore. Allow Loctite to set-up for 5 to 10 minutes before removing tool. Press outer seal into motor support housing using same procedure.

#### **!! CAUTION !! SEALS MUST BE LOCATED AND ORIENTED AS SHOWN IN UNI-VAC VACUUM BOOSTER DWG. REF:EXPLODED VIEW & SECTIONAL VIEW.**

4.5.4 Install “O” ring in sleeve, assemble sleeve on shaft. Sleeve must be tight against shoulder.

4.5.5 Clean housing faces and covers with gasket remover. Apply thin bead of sealant Loctite gasket eliminator between seal housing and bearing housing.

4.5.6 Apply tape over keyway slot. Slide seal housing over drive shaft, hold housing square with shaft to prevent damage to seals, engage dowel pins in bearing housing and tap seal housing firmly in place.

4.5.7 Secure seal housing to pump body flange with Hex. head cap screws. Torque all bolts to 13 ft. lbs.

**Note:** When installing new oil seals in the belt driven blower , refer to section

4.2 for blower with the old style casting, and for blower with the new style casting and new style reservoir cover.

#### 4.6 Painting

**4.6.1** If blower is repainted, care must be taken to mask vent slots on the motor to prevent paint spray from coating the motor armature. Care must also be taken not to paint over the vent hole in vent plug.

#### 4.7 SEAL INSERTION TOOL

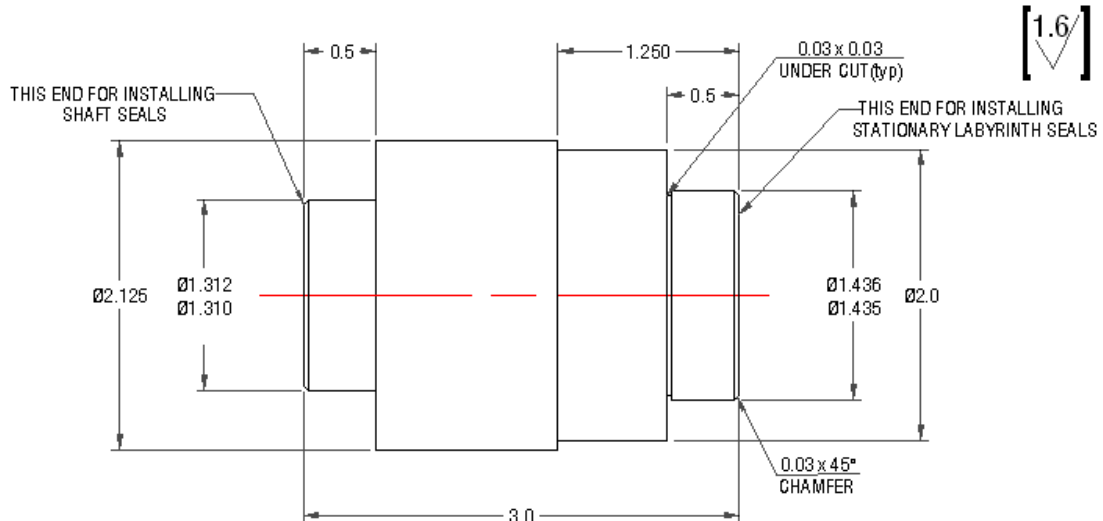

#### NOTES:

1. ALL DIMENSIONS ARE IN INCHES
2. BREAK ALL SHARP EDGES
3. H.T. TO 269-310 B.H.N.(4140 H.T.STEEL)

PART NAME: SEAL INSERTION TOOL  
PART No.: UV-429-606-002

#### 4.8 Seal parts kits – direct drive blower/ belt drive blower

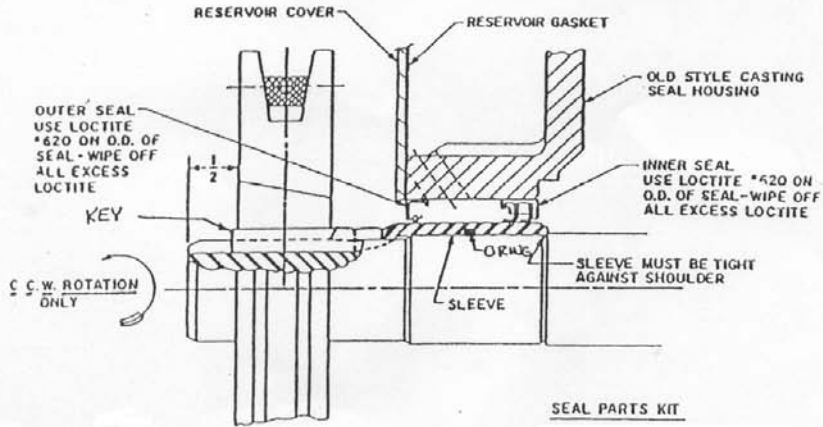

BELT DRIVE BLOWER

SEAL PARTS KIT

UV-424-089-001 CONSISTS OF  
 INNER SEAL  
 OUTER SEAL  
 SLEEVE & "O" RING

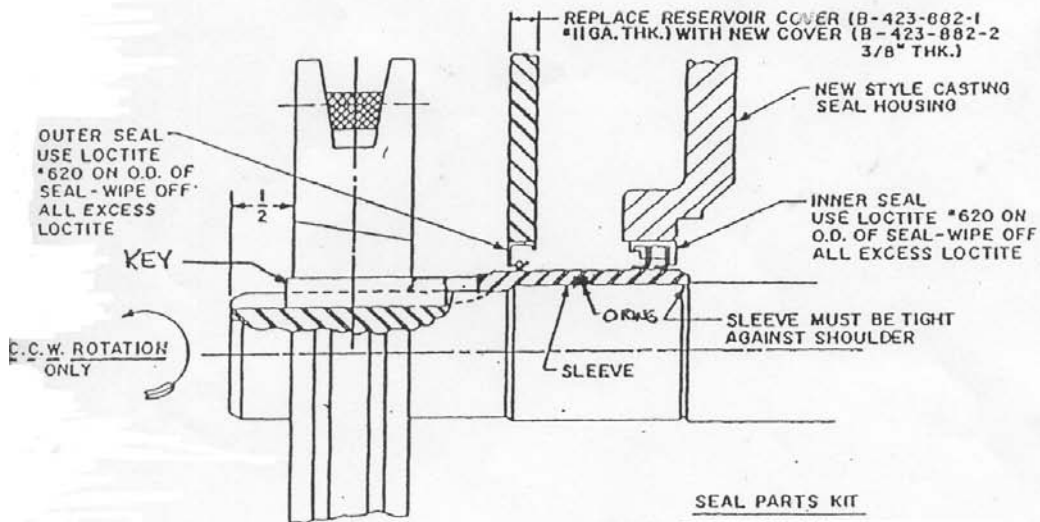

BELT DRIVE BLOWER

SEAL PARTS KIT

UV-424-089-001 CONSISTS OF  
 INNER SEAL  
 OUTER SEAL  
 SLEEVE & "O" RING



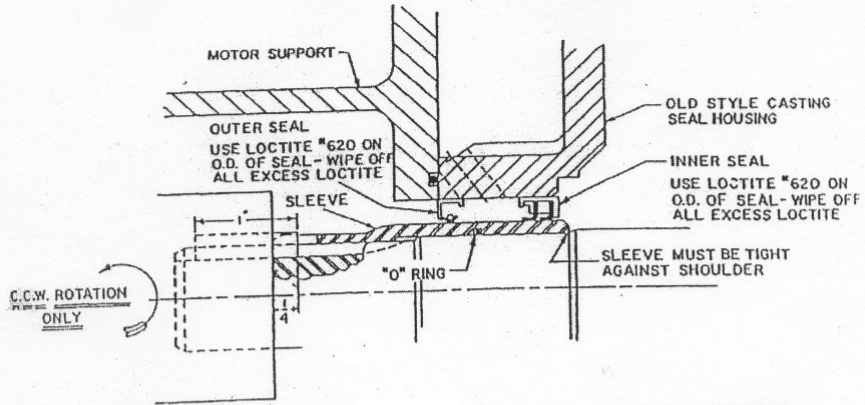

DIRECT DRIVE BLOWER

SEAL PARTS KIT  
 UV-424-090-001 CONSISTS OF  
 INNER SEAL  
 OUTER SEAL  
 SLEEVE & "O"RING

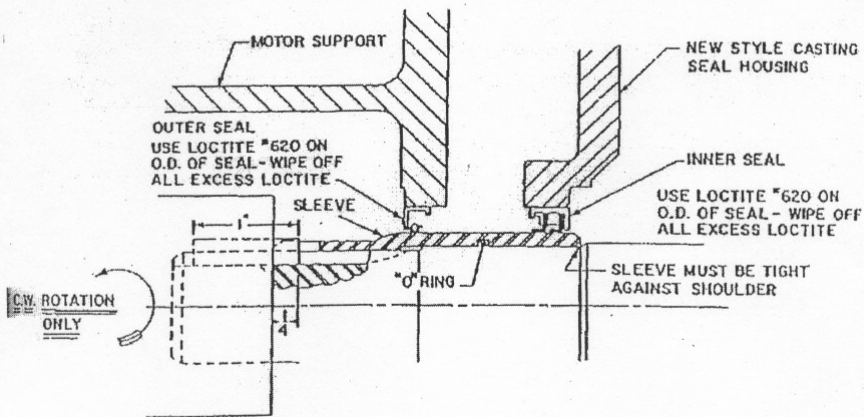

DIRECT DRIVE BLOWER

SEAL PARTS KIT -  
 UV-424-090-001 CONSISTS OF  
 INNER SEAL  
 OUTER SEAL  
 SLEEVE & "O"RING



## **5.0 OXYGEN SERVICE**

5.0.1 It is recommended that any major repairs needed for the oxygen service booster should be in our plant.

5.0.2 Minor repairs such as replacement of lip seals can be made in the field. Because of the possibility of a dangerous reaction to dirt and chemical compositions in an oxygen rich environment, absolute cleanliness of parts, tools, wipers and even assembler's hands and clothes is required.

5.0.3 General guidelines for oxygen service booster.

1. All parts should be inspected for burrs before cleaning.
2. All stored, cleaned parts must be covered with plastic to maintain cleanliness.
3. Work area, tools and fixtures should be free of grease and oils.
4. Use clean "paper wipes" only (no cloth).
5. Use Oxy-8 paste on all threaded pipe and fittings. (Do not use Permatex, Loctite or Teflon paste).
6. Hand and assembly tools should be lightly coated with recommended oils to prevent contamination of parts during assembly. See Section 2.4.2, for recommended oils.
7. Ball bearings and lip seals should be cleaned and free of grease and oil. Apply light film of halocarbon oil in bearings after cleaning.
8. No rust preventive oils should be used on any oxygen service parts.

\* \* \*

## 300 SERIES BLOWERS

### EXPLANATION OF THE 300 SERIES BLOWERS

The 300 Series Blowers cover the following models :

- UV-900-300-001 : Vertical Flow Direct Drive Blower without By Pass Valve
- UV-900-300-002 : Vertical Flow Belt Drive Blower without By Pass Valve
- UV-900-300-003 : Horizontal Flow Blower, Foot Mounting, Direct Drive, without By pass Valve
- UV-900-300-004 : Horizontal Flow Blower, Foot Mounting, Belt Drive, without By Pass Valve
- UV-900-300-001 : Vertical Flow Direct Drive Blower with By Pass Valve
- UV-900-300-002 : Vertical Flow Belt Drive Blower without By Pass Valve
- UV-900-300-003 : Horizontal Flow Blower, Foot Mounting, Direct Drive, without By pass Valve
- UV-900-300-004 : Horizontal Flow Blower, Foot Mounting, Belt Drive, without By Pass Valve

\* \* \*

| <b>300 SERIES PART LIST</b> |                    |                 |  |
|-----------------------------|--------------------|-----------------|--|
| <b>Sl.no</b>                | <b>Qty./ assy.</b> | <b>Part No.</b> | <b>Description</b>   |
| 1                           | 1                  | UV-604-382-002  | Valve cap (for 300 Series)   |
| 2                           | 1                  | UV-604-381-002  | Valve piston (for 300 Series)  |
| 3                           | 2                  | UV-604-469-001  | Ring Stroke limit-Metallic   |
| 4                           | 2                  | UV-604-469-002  | Ring Stroke limit -Teflon  |
| 5                           | 1                  | UV-423-898-001  | 300 Series Motor support   |
| 6                           | 2                  | UV-424-694-009  | Bearing housing  |
| 7                           | 3                  | UV-425-019-001  | Spacer - shaft   |
| 8                           | 2                  | UV-425-651-006  | Key -gear  |
| 9                           | 1                  | UV-424-698-004  | Gear cover   |
| 10                          | 1                  | UV-424-697-004  | Seal housing   |
| 11                          | 1                  | UV-424-695-001  | Pump body 3.25" (for 306)  |
| 12                          | 1                  | UV-424-696-008  | Pump body 3.25" (for 310)  |
| 13                          | 1                  | UV-423-898-001  | Blower manifold  |
| 14                          | 1                  | UV-429-296-005  | Shaft sleeve   |
| 15                          | 1                  | UV-429-296-007  | Shaft sleeve - for gear  |
| 16                          | 3                  | UV-425-011-002  | Bearing retainer plate   |
| 17                          | 1                  | UV-424-667-001  | Clamp collar   |
| 18                          | 1                  | UV-085-040-006  | 2 Pole, 3 Phase, Induction Motor, Flange mounted, 1.5H.P, 1800 r.p.m.      |
| 19                          | 1                  | UV-085-041-926  | 2 Pole, 3 Phase, Induction Motor, Flange mounted, 5 H.P, 3600 r.p.m.       |
| 20                          | 1                  | UV-430-289-012  | Compression Spring- Ø61.10 mm OD x 162.0mm Free length xØ3.20 mm wire dia. |
| 21                          | 4                  | UV-425-037-001  | Labyrinth seal - rotating  |
| 22                          | 4                  | UV-425-016-002  | Labyrinth seal - fixed   |
| 23                          | 1                  | UV-425-256-002  | Flinger – drive end  |
| 24                          | 1set of 2          | UV-085-038-257  | Gear helical - Ø3.25"  |
| 25                          | 1                  | UV-423-872-010  | Impeller drive (for 300 Series)  |
| 26                          | 1                  | UV-423-874-008  | Impeller driven (for 300 Series)   |
| 27                          | 1                  | UV423-871-011   | Impeller drive (for 300 Series)  |
| 28                          | 1                  | UV423-873-008   | Impeller driven (for 300 Series)   |
| 29                          | 1set of 2          | UV-085-042-280  | Love joy coupling 1.1/8" x 1.1/16" - L-095 Ø1.062" ID                      |

|    |           |                |   |
|----|-----------|----------------|---|
| 30 | 1set of 2 | UV-085-042-281 | Love joy coupling for shaft (1.1/8" x 1.1/16" L-095, Ø0.875" ID)    |
| 31 | 1set of 2 | UV-085-042-282 | Love joy coupling for motor shaft (1.1/8"x11/16"L-095, Ø0.9461" ID) |

| <b>300 SERIES PART LIST</b> |                    |                 |  |
|-----------------------------|--------------------|-----------------|--|
| <b>Sl.no</b>                | <b>Qty./ assy.</b> | <b>Part No.</b> | <b>Description</b>                                       |
| 32                          | 1                  | UV-429-905-005  | Breather vent plug                                       |
| 33                          | 2                  | UV-075-040-031  | Plug viton O ring (bearing housing)                      |
| 34                          | 1                  | UV-075-040-263  | Plug viton O ring (Seal housing)                         |
| 35                          | 3                  | UV-085-040-332  | Gauge sight level window type ½" x 14TPI, NPT            |
| 36                          | 1                  | UV-603-282-003  | 'DU" Bush – valve cap (1.75" OD x 1.50" ID x 2.0" L)     |
| 37                          | 8                  | UV-085-038-847  | Shim RD ST 0.003 x 1.1/8" ID                             |
| 38                          | 4                  | UV-085-038-846  | Shim RD ST 0.005 x 1.1/8" ID                             |
| 39                          | 1                  | UV-085-038-845  | Shim RD ST 0.01x 1.1/8" ID (                             |
| 40                          | 1                  | UV-085-038-844  | Shim RD ST 0.015 x 1.1/8" ID                             |
| 41                          | 1                  | UV-085-039-031  | Shim RD ST 0.032 x 1.1/8" ID                             |
| 42                          | 1                  | UV-085-040-116  | Oil seal 1.3/8" ID x 0.70 Sec.                           |
| 43                          | 1                  | UV-085-040-198  | Oil seal 1.375 x 1.875                                   |
| 44                          | 1                  | UV-085-040-199  | 1.1/8" ID x 0.70 sec.                                    |
| 45                          | 2                  | UV-075-033-472  | Fill plug viton O ring                                   |
| 46                          | 3                  | UV-085-037-646  | Ball Bearing B RAD DBL 1.1811 ID / MRC 5206C USA 11 214B |
| 47                          | 1                  | UV-085-037-645  | Ball Bearing RADIAL SGL ROW / FAFNR Z06KC2 FS 50000 USA  |
| 48                          | 1                  | UV-085-044-471  | O' ring – for Blower manifold Ø2.5MM x Ø116.0mm OD.      |
| 49                          | 4                  | UV-085-037-653  | Washer - wave 1.543"ODx1.201"IDx1/64" T                  |
| 50                          | 3                  | UV-423-894-001  | Washer   |

|    |   |                |   |
|----|---|----------------|---|
| 51 | 1 | UV-085-043-117 | O' Ring - Viton 3.986" ID x Ø1/16" – for valve piston |
| 52 | 1 | UV-085-044-470 | O' Ring - Viton 4.737" ID x Ø3/32" – for Valve cap.   |

| <b>300 SERIES PART LIST (FASTENERS)</b> |                    |                               |  |
|---|--------------------|-------------------------------|--|
| <b>Sl.no</b>                            | <b>Qty./ assy.</b> | <b>Description</b>            | <b>Spec./ size</b>   |
| 1                                       | 4                  | Hex. Hd. NPT Plug             | Hex. Hd. NPT Plug 1/4" x 18 TPI, NPT   |
| 2                                       | 6                  | Hex. Hd. Bolt                 | Hex. Hd. Bolt 3/8" x 16 UNC x 1" L   |
| 3                                       | 2                  | Hex Soc Hd Shoulder Screw     | Hex Soc Hd Shoulder Screw Ø3/8" shoulder dia.x 1" thread length 0.5"L<br>5/16" x 18 UNF x 3/8" L |
| 4                                       | 2                  | Grub screw                    | Grub screw 5/16" x16 UNC x 3/8" L  |
| 5                                       | 4                  | Hex. Hd. Bolt                 | Hex. Hd. Bolt 3/8" x 16 UNC x 1.1/4" L   |
| 6                                       | 24                 | Hex. Hd. Bolt                 | Hex. Hd. Bolt 5/16"x18 UNC x 3" L  |
| 7                                       | 8                  | Hex. Hd. Bolt                 | Hex. Hd. Bolt3/8" x 16 UNC x 1.1/4" L  |
| 8                                       | 12                 | Slotted Pan Hd. Machine screw | Slotted Pan Hd. Machine screw1/4" x 1/2" L   |
| 9                                       | 28                 | Spring washer                 | Spring washer Ø5/16"   |
| 10                                      | 4                  | Hex. Hd. Bolt                 | Hex. Hd. Bolt 1/4" x20 UNC x 11/16" L  |