



Trillium US Inc.
Model 700 Water Cooled Cryogenic Helium Compressor
User's Manual
Rev E / August 2017



For information about Trillium US Inc., visit the Trillium US Inc. Web site at:

<http://www.trilliumus.com>

How to Contact Trillium US Inc. Support:

support@trilliumus.com

For contact information and a complete listing of Direct Sales, Distributor, and Sales Representative contacts, visit the Trillium US Inc. Web site at:

<http://www.trilliumus.com>

Trillium US Inc. has made its best effort to ensure that the information contained in this document is accurate and reliable. However, the information is subject to change without notice and is provided "AS IS" without warranty of any kind (express or implied). Before placing orders, customers are advised to obtain the latest version of relevant information to verify that information being relied upon is current and complete. All products are sold subject to the terms and conditions of sale supplied at the time of order acknowledgment, including those pertaining to warranty, patent infringement, and limitation of liability. No responsibility is assumed by Trillium US Inc. for the use of this information, including use of this information as the basis for manufacture or sale of any items, nor for infringements of patents or other rights of third parties. This document is the property of Trillium US Inc. and by furnishing this information, Trillium US Inc. grants no license, expressed or implied, under any patents, copyrights, trademarks, trade secrets, or other intellectual property rights of Trillium US Inc. Trillium US Inc., copyright owner of the information contained herein, gives consent for copies to be made of the information only for use within the customer's organization as related to the use of Trillium US Inc. products. The same consent is given for similar information contained on any Trillium US Inc. Web site or disk used to distribute information to a customer. Trillium US Inc. does give consent to the copying or reproduction by any means of the information contained herein for general distribution, advertising or promotional purposes, or for creating any work for resale. The names of products of Trillium US Inc. or other vendors and suppliers appearing in this document may be trademarks or service marks of their respective owners that may be registered in some jurisdictions. A list of Trillium US Inc. trademarks and service marks can be found at:

<http://www.trilliumus.com/>

Trillium US Inc.
1340 Airport Commerce Dr.
Bldg. 1 Suite 175
Austin, Texas 78741 USA
TEL. +1 512 441 6893
FAX +1 512 443 6665
Email: insidesales@trilliumus.com

Copyright (©) 2015 by Trillium US Inc., All rights reserved.



Table of Contents

- 1 Revision History..... vi
- 2 Preface 1
 - 2.1 About Trillium US Inc..... 1
 - 2.2 Other Services from Trillium US Inc. 1
 - 2.3 About this Manual..... 1
 - 2.4 Compatibility 1
- 3 Safety Warnings 2
 - 3.1 Standards for the Use of Warnings and Cautions 2
 - 3.2 Warnings Applicable to All Aspects of M700 Operation 2
 - 3.2.1 High Voltage and Electrical Shock Warnings 2
 - 3.2.2 High Pressure Related Warnings 3
 - 3.2.3 Helium Gas-Related Warnings..... 3
 - 3.2.4 Heat-Related Warnings 3
 - 3.3 Operator Instructions..... 4
- 4 Introduction 4
 - 4.1 General Information about the Model M700 Compressor 4
 - 4.1.1 Model M700 Features 4
 - 4.1.2 Overview of Model M700Compressor Design & Operation..... 4
 - 4.1.3 Description of Subsystems 5
 - 4.1.4 Operational Flow 6
 - 4.2 Specifications 6
 - 4.3 Configurations 8
 - 4.4 Ordering Information 10
- 5 Installation..... 10
 - 5.1 Safety Warnings 10
 - 5.2 Installation Steps..... 11
 - 5.2.1 Unpacking and Inspection 11
 - 5.2.2 Mounting the Compressor 11
 - 5.2.3 Preparing the Compressor for Operation..... 11
 - 5.2.4 Installation..... 12
 - 5.2.5 Electrical Connection 13
- 6 Operation 15
 - 6.1 Before Switching ON the System..... 15
 - 6.2 Normal Operation 15
 - 6.2.1 Cycle Times 15
 - 6.3 Electronics Interface Connections..... 15



6.3.1	Remote Interface	16
6.3.2	D-Sub User Controls	16
6.3.3	D-Sub User Status	17
6.3.4	Compressor Front Panel User Interface	18
6.3.5	Compressor Operational Checks	19
6.3.6	Compressor Maintenance Warning.....	20
6.3.7	Compressor System Shutdown.....	20
6.3.8	Compressor Interfaces.....	20
6.3.9	Serial Communications via R232	21
6.3.10	Communications via USB.....	23
7	Troubleshooting	28
7.1	Troubleshooting Activities.....	28
8	Maintenance	30
8.1	Maintenance Personnel Requirements.....	30
8.2	Removing the Compressor from Service: Removal, Transport and Storage	30
8.3	Scheduled Preventative Maintenance Activity	30
8.3.1	Remove the Compressor Adsorber	31
8.3.2	Install Replacement Adsorber	34
8.4	Unscheduled Corrective Maintenance.....	34
8.4.1	Removing Helium Contamination.....	35
8.5	Returning Equipment	35

List of Figures

Figure 1 – M700 Temperature vs. Recommended Water Flow Rate	7
Figure 2 – M700 Standard Drive	8
Figure 3 – M700 On-Board Drive	8
Figure 4 – M700 Low Volt Multi-Drive	9
Figure 5 – M700 High Volt Multi-Drive	9
Figure 6 – M700 Helium Compressor Control Voltage Transformer Tap Settings.....	14
Figure 8 – User Control Signal Interface	17
Figure 9 – User Status Signal Interface	18
Figure 10 – Removal of Top Cover and Rear Panels	32
Figure 11 – Adsorber Aeroquip Connection Points	32
Figure 12 – Adsorber Removal.....	33
Figure 13 – Self Sealing Connector	34
Figure 14 – M700 Water Piping and Instrumentation Diagram	36
Figure 15 – M700 Water General Dimensions.....	37
Figure 16 – M700 Water Low Volt Standard Drive Schematic.....	38
Figure 17 – M700 Water High Volt Standard Drive Schematic.....	39
Figure 18 – M700 Water Low Volt Onboard Drive Schematic	40
Figure 19 – M700 Water Low Volt Multi-Drive Schematic	41
Figure 20 – M700 Water High Volt Multi-Drive Schematic	42
Figure 21 – M700 Fault Tree: Compressor will Not Start / Adsorber Replacement	43



Figure 22 – M700 Fault Tree: Compressor Starts but Shuts Off 44
 Figure 23 – M700 Fuse Locations for Electronics Boxes in Figure 2 and Figure 3 45
 Figure 24 – M700 Fuse Locations for Electronics Boxes in Figure 4 and Figure 5 46
 Figure 25 – 99-00074-000 Tool Kit Contents 47
 Figure 26 – 99-00074-001 Tool Kit Contents 48
 Figure 27 – 99-00250-000 Kit Contents 49

List of Tables

Table 2-1: Model M700 Helium Compressor Coldhead Compatibility 2
 Table 2-2: Model M700 Helium Compressor Cryopump Compatibility..... 2
 Table 4-1: Description of Model M700 Helium Compressor Subsystems 5
 Table 4-2: Power Requirements for Model 700 Compressor 6
 Table 4-3: Model 700 Helium Compressor Specifications 6
 Table 4-4: Model 700 Helium Compressor Pressure Requirements..... 7
 Table 4-5: Model 700 Water Cooled Helium Compressor Ordering Information..... 10
 Table 4-6: Optional Accessories and Replacement Parts 10
 Table 6-1: J1 or J3 Remote Connector (25-Pin D-Sub) 16
 Table 6-2: Remote Interface Inputs for Electrical Boxes Shown in Figure 4 and Figure 5 17
 Table 6-3: Remote Interface Outputs for Electrical Boxes Shown in Figure 4 and Figure 5 18
 Table 6-4: Model 700 Optional Checks 19
 Table 6-5: Serial Port Interface Pin Assignments 20
 Table 6-6: Serial Port Cable 21
 Table 6-7: Serial Port Commands 21
 Table 6-8: Data Message 21
 Table 6-9: Command/Data 22
 Table 6-10: Error Codes 22
 Table 6-11: USB Packet format 23
 Table 6-12: USB Maintenance Interface Command ID's 23
 Table 6-13: ACK Payload Format 24
 Table 6-14: NACK Payload Format 24
 Table 6-15: NACK Reason Codes 24
 Table 6-16: Get Status Payload Format 24
 Table 6-17: Status Response Payload Format 25
 Table 6-18: Get Fault History Payload Format 26
 Table 6-19: Fault History Response Payload Format 26
 Table 6-20: Fault Codes 26
 Table 6-21: Set Compressor Payload Format 26
 Table 6-22: Set Coldhead Payload Format 27
 Table 6-23: Reset Payload Format 27
 Table 6-24: Get Version Payload Format 27
 Table 6-25: Version Response Payload Format 27
 Table 7-1: Trouble Shooting Procedures 28
 Table 7-2: Fuse Listing for Electronics Boxes in Figure 2 and Figure 3 29
 Table 7-3: Fuse Listing for Electronics Boxes in Figure 4 and Figure 5 29



1 Revision History

Date	Revision	ECR #	Description of Change
March 2012	A		Production Release
September 2012	B		Document update, minor error correction
May 2016	C	2887	Rebranding, formatting updates, specification change
February 2017	D	2981	Pg i: email address change Revised Table 2-1, Table 2-2, Table 4-1, Table 4-2, Table 4-3, Table 4-5, Table 4-6, Figure 20, Figure 21 Add Sections: 4.3, 6.3.4.1, 6.3.5.1, 6.3.8.2, 6.3.10 Added Figure 18, Figure 19 and Figure 23, Figure 26
August 2017	E	3044	Revise Figure 19 Add Section 6.3.6, add paragraph to section 8.3, add step to section 8.3.2
Document Part Number: 97-00052-000			



2 Preface

2.1 About Trillium US Inc.

Trillium US Inc., an Oregon based company, specializes in the manufacture and repair of cryogenic vacuum pumps, cryocoolers (refrigerators) and helium compressors for semiconductor, optical coating, linear accelerators, medical equipment, and R&D applications.

You can find just what you need from our range of products and support services:

- New Equipment - cryopumps, compressors, cryocoolers, and cryopump controllers such as the Model 700 Water Cooled Helium Compressor described in this manual.
- Comprehensive range of accessories for the installation of whole systems and a complete range of spare parts to repair cryopumps and compressors.

2.2 Other Services from Trillium US Inc.

Trillium US Inc. offers comprehensive refurbishment services for its own equipment as well as for that of most of our competitors. Our products and services are available through our global network of agents and dealers.

- Repair and refurbishment services - We offer our own quality products, as well as most other manufactures models, often with off-the-shelf availability.
- Exchanges - We offer our own quality products, as well as most makes of cryopumps and helium compressors, which are refurbished and fully warranted.
- Technical Support - Our support engineers will help determine if your cryopump system is operating correctly so that you can get your system back to optimum efficiency as soon as possible.
 - To contact Trillium US Inc. Technical Support:
 - E-mail: support@trilliumus.com
 - Telephone: 1-512-441-9258 or Toll Free: 1-800-404-1055
- Installation - On-site installation services are available to guarantee performance and save you time.
- Training - We offer on-site training to help you and your staff to know more about your cryopump and compressor systems. Our training will give you confidence and the ability to maintain a highest possible uptime for your system.

2.3 About this Manual

The purpose of this manual is to provide our customers using the Model 700 Helium Compressor with the information needed to safely and efficiently operate the compressor when operating as part of a cryogenic refrigeration system. Such a system is often comprised of the following equipment:

- Model M700 Water Cooled Helium Compressor
- Coldhead(s) or cryopump(s)
- Connecting helium lines

This manual describes the design, operation and maintenance of the Model M700 water cooled helium compressor unit.

2.4 Compatibility

Trillium US Inc. Model M700 Water Cooled Helium Compressors are compatible with various cold heads and cryopumps described in **Table 2-1** and **Table 2-2**. Each Model M700 water cooled compressor unit can be used to run one or more such cryopumps or cold heads. For other combinations than listed below, please contact Trillium US Inc. Technical Support using the contact information found in Section **2.2**.



Table 2-1: Model M700 Helium Compressor Coldhead Compatibility

Model M700 Drive Unit Electrical Circuit Configuration	Cold Head Model (Manufacturer)	Number of Multiple Cold Heads Allowed	
		50 Hz	60 Hz
Scott "T"	350CS (TUI)	4	5
	1020CS (TUI)	3	3
	1050CS (TUI)	1	2
	350CP (CTI)	4	5
	1020CP (CTI)	3	3
	1050CP (CTI)	1	2

Table 2-2: Model M700 Helium Compressor Cryopump Compatibility

Model M700 Drive Unit Electrical Circuit Configuration	Cryopump Model (Manufacturer)	Number of Multiple Cryopumps Allowed	
		50 Hz	60 Hz
Scott "T"	CP8/CP8LP (TUI)	4	5
	CP10 (TUI)	3	3
	CP16 (TUI)	1	2
	CT8/CT8F (CTI)	4	5
	CT10 (CTI)	3	3
	CT400	1	2
	CT500	1	1
On-Board	OB-8/OB-8F (CTI)	4	5
	OB-250F (CTI)	3	3
	OB-10 (CTI)	3	3
	OB-400 (CTI)	1	2
	OB-500 (CTI)	1	1

3 Safety Warnings

3.1 Standards for the Use of Warnings and Cautions

Warnings are noted when there is a possibility of injury or death to persons operating the equipment or performing specific tasks or procedures noted in this manual. Cautions are noted when there is a possibility of damage to equipment if the caution is ignored.

3.2 Warnings Applicable to All Aspects of M700 Operation

3.2.1 High Voltage and Electrical Shock Warnings



This unit can start automatically, and via remote control. Potentially fatal voltages are present in the compressor unit. The compressor should be switched off and disconnected from its power supply before carrying out any troubleshooting or maintenance activities on the unit.



Connect or disconnect the flex lines joining the compressor and its load (cryopump, coldhead, etc) only after the compressor and its load are switched off and separated from the power source. Otherwise, electrical shock hazards may exist, potentially causing damage to the compressor unit, its load, or the operator.





Always provide proper grounding to the compressor unit and its load. All electrical power connection and disconnection of the unit should be done by a qualified electrician.



High voltage is present within the compressor unit and can cause severe injury from electrical shock. Permit only qualified electrical technicians to open the compressor enclosure to perform electrical troubleshooting.



The main power plug is used as the overall disconnect device. Ensure that access to the disconnect device is made available at all times.



The covers must be secured in place before powering up or operation; exposed electrical devices are accessible with the covers removed.

3.2.2 High Pressure Related Warnings



High gas pressure is present within the system and may cause severe injury if a safe pressure level is exceeded.



Do not charge the compressor without using a pressure regulator. Do not charge the compressor to a pressure level that exceeds limit set by the manufacturer.



The static pressure of a compressor is predetermined by the manufacturer based on operational safety and performance considerations. Do not exceed this level when charging a compressor.

3.2.3 Helium Gas-Related Warnings



Helium gas can cause rapid asphyxiation and death if released in a confined and un-ventilated area.



Use a pressure reducing regulator when withdrawing helium gas from a high-pressure gas cylinder.



Detaching the helium flex lines when the compressor load is at low temperature may cause the pressure to rise in the system beyond the permissible level therefore creating a safety hazard.

3.2.4 Heat-Related Warnings



The compressor motor may become hot during operation. Wait for the motor to cool down before working inside the compressor.



3.3 Operator Instructions

Follow standard Model M700 Helium Compressor operating procedures as described in this manual. If you still have questions regarding the safe operation of the M700 Helium Compressor, please contact Trillium US Inc. Technical Support using the contact information found in Section 2.2.



If the equipment is used in any manner not specified by the manufacturer, the protection provided by the equipment may be impaired.



Turn the main power off before switching the coldhead phase or voltage selection switches.



Maintenance personnel must verify safe state of equipment after all repairs.

4 Introduction

4.1 General Information about the Model M700 Compressor

Trillium US Inc. offers industry-proven compressors such as the Model M700 Water Cooled Helium Compressor described in this manual, at highly competitive prices, and with flexible configurations. Included with each order shall be the following.

- Model M700 Water Cooled Helium Compressor
- Remote connector kit
- Female charge (¼" Aeroquip to ¼" flare connector) fitting
- Compressor Manual (electronic download)

4.1.1 Model M700 Features

The Model M700 Water Cooled Helium Compressor is designed for tens of thousands of hours of continuous operation. The main features of the Model M700 Water Cooled Helium Compressor are:

- Minimal maintenance requirements
- Integrated water flow meter
- Reliable helium and oil management system
- Front-mounted low and high pressure gauges
- Rack mounting option, which is ideal for vacuum coating/ion implanters, semiconductor vacuum systems, CAT scanners, MRI systems and sputtering system applications.

4.1.2 Overview of Model M700 Compressor Design & Operation

Model M700 Water Cooled Helium Compressor is designed to run different cryopump or coldhead models from different manufacturers (see **Table 2-1** and **Table 2-2** for compatibility information), for either high voltage or low-voltage and 60/50 Hz three-phase operations.

The compressor itself consists of five main components:

- Compressor capsule (motor)



- Heat exchanger
- Oil mist (vapor) separator
- Bulk oil separator
- Adsorber

The compressor unit and the coldhead are connected by way of helium gas flex lines. The compressor unit, coldhead, and helium lines are fitted with self-sealing couplings, and are charged with ultra high-purity (99.999%) helium gas (He 5.0 UH).

Helium gas is pumped through the compressor motor and after being compressed to a higher pressure, the oil is mixed with the helium. The oil acts (in addition to the primary function as a lubricator) as the medium to remove heat created by compressing the helium gas from the compressor motor. Once exiting the compressor motor, the hot oil/hot helium mixture is pumped via differential pressure through the bulk oil separator. As the oil mixture passes through the oil mist separator, the vast majority of hot oil and hot helium is separated, such that each medium (helium and oil) enters the heat exchanger through different parallel paths.

The heat exchanger removes the heat generated from the process of compressing helium in the capsule. Similar to the bulk oil separator, the helium gas as well as oil is then pumped by way of differential pressure through the air-cooled heat exchanger. The cooled oil returns to the capsule to lubricate and cool the capsule.

The second stage of helium gas purifying occurs after the heat removal and cooling process. Helium gas purification must occur because the helium out of the heat exchanger still has a small amount of oil vapor mixed with it. If this helium gas gets to the cryopump with oil vapor in it, the oil will freeze and contaminate the cryopump. The function of the oil mist (vapor) separator is to rid the helium gas stream of this oil vapor. Any oil condensate is then returned to the capsule.

Typically, the helium gas still contains a trace amount of oil vapor at this point. The adsorber then filters out the remaining oil vapor from the helium gas stream. Over time, the adsorber will become saturated with the oil vapor. Thus, it is important that the adsorber be replaced according to the recommended replacement interval found in section 8.3.

4.1.3 Description of Subsystems

Along with the five main components, **Table 4-1** describes the subsystems that serve to monitor the operating condition of the compressor unit and to ensure its safe operation.

Table 4-1: Description of Model M700 Helium Compressor Subsystems

Subsystem Name	Function
Phase rotation monitor	Purpose: Monitors the phase of the input power. Will not allow operation if the phase is incorrect.
Internal line break motor protector	An internal line break motor protector, located in the center of the Y of the motor windings, disconnects all three phases in case of an overload condition. The internal protector protects against single phasing
Overload relay	Purpose: Monitors system current. Will turn off the compressor if the current level exceeds the pre-set value
Thermal switch (TS1)	Purpose: Monitors helium temperature upstream of the heat exchanger. Safety Function: Will turn off the compressor if the helium temperature gets above 210°F (99°C)
Thermal Switch (TS2)	Purpose: Monitors oil temperature downstream of the heat exchanger. Safety Function: Will turn off the compressor if the oil temperature gets above 180°F (82°C)



Subsystem Name	Function
Unloading valve	Purpose and Safety Function: Equalizes pressure within the compressor unit upon power interruption
Oil check valve	Purpose and Safety Function: Prevents oil migration when power is off
Cooling water flow meter	Purpose: Allows a visual reference as to the current flow rate of the cooling water. 1.6 – 2.0 GPM is required.
Fuses: Fuses for the coldhead drive circuit Fuses for the main input power Fuses for the control voltage Fuses for the fan motors Fuses for the main contactor coil	Safety Function: Over-current protection See Table 7-2 and Table 7-3 for fuse details
Internal relief valve	Purpose and Safety Function: Opens a shunt between the high and low-pressure helium gas circuits. Sets the proper operating pressure for the system regardless of the load. Safety Function: If the differential pressure exceeds a preset value, this valve opens to allow safe operation.
External relief valve	Purpose and Safety Function: Opens the helium gas circuit to atmosphere if the helium gas pressure exceeds 430 PSIG (29.6 Bar)
Low pressure switch	Safety Function: Will turn off the compressor if the Return pressure is equal to or lower than 15 PSIG (1.03 Bar).
High pressure switch	Safety Function: Will turn off the compressor if the Supply pressure is equal to or higher than 430 PSIG (29.6 Bar).

4.1.4 Operational Flow

The flow diagram for the Model M700 Helium Compressor is illustrated in **Figure 13**.

4.2 Specifications

The Model M700 Helium Compressor specifications are listed in **Table 4-2** and **Table 4-3**.

Table 4-2: Power Requirements for Model 700 Compressor

Model	Rated Operating Voltage (VAC)	Frequency (Hz)	Phase	Max Current Draw (A)	Max Power (kW)*
COMP, M700, HV, WATER, MULTI DRIVE	380-420	50	3	17	9.9
	460	60	3	17	11.4
COMP, M700, LV, WATER, MULTI DRIVE	200-230	50	3	31	9.8
	220-230	60	3	31	10.2

*Nominal Power Factor = 0.85

Table 4-3: Model 700 Helium Compressor Specifications

Feature/Component	Specification Description
Physical Dimensions	See Figure 14
Weight	320 lbs. (145 kg)
Helium Pressure	See Table 4-4
Interface	Compressor power cord has bare leads



Feature/Component	Specification Description
	Cold Head Power: MS3102A14S-6S or MS3102A18-19S (dependent on version) Remote Connector: TE 3-1634224-2 Helium connections: 1/2 inch male Aeroquip couplings
Facility Requirements	Electrical Service Breaker: 20 Amp minimum (HV)/ 40 Amp minimum (LV) <i>(The end user shall size the branch circuit over current protective device to protect the equipment. This equipment does not have a primary protective branch over current device.)</i> Maximum Fault current to the system should not exceed 5000 amps.
Adsorber Replacement Schedule	15,000 Hours (per elapsed time meter on the compressor) or 2 years, whichever comes first (see Section 8.3)
Cooling Water	1.6 – 2.0 GPM (6.0 – 7.6 liter/minute) minimum flow rate 65°F - 80°F (18.3 – 26.7°C) inlet water temperature See Figure 1 Recommended water chiller capacity: 2.5 tons/per compressor unit Water line connector: 3/8 inch Swagelok tube fittings (adapters available)
Ambient Air	40°F - 104°F (5°C - 40°C)

Table 4-4: Model 700 Helium Compressor Pressure Requirements

Description	Value (PSIG)	Value (Bar)
Static Pressure @ 50 Hz	200 ± 10	13.78 ± 0.69
Static Pressure @ 60 Hz	200 ± 10	13.78 ± 0.69
Operating Pressure (Differential; no load)	240 - 260	16.5– 17.9

Figure 1 – M700 Temperature vs. Recommended Water Flow Rate

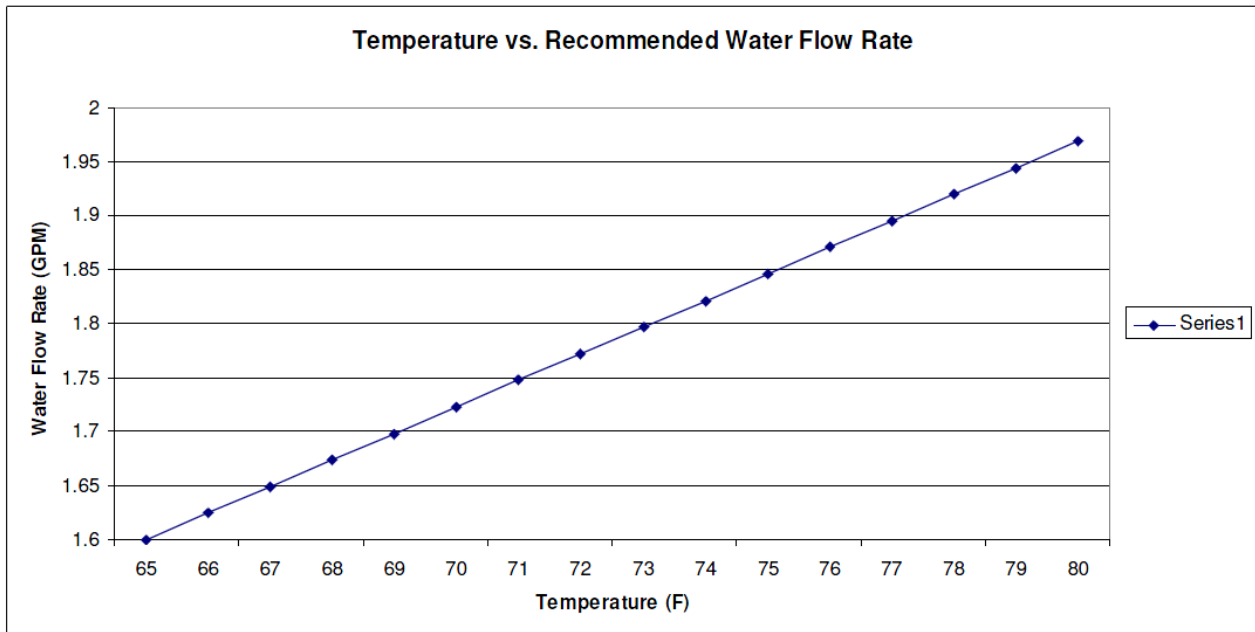

4.3 Configurations

Due to its length of time on the market the M700 Water Compressor has two configurations of its electronics module available and in use by customers. The following figures will help the user identify their configuration and thus which electrical interfaces, schematics and trouble-shooting areas to refer to when needed.

Figure 2 – M700 Standard Drive

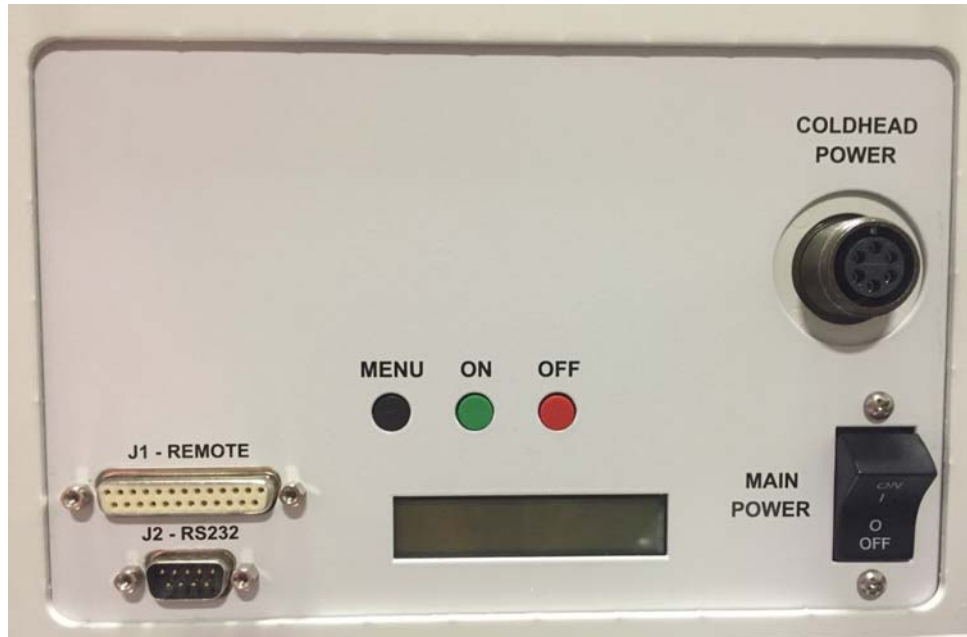

Figure 3 – M700 On-Board Drive

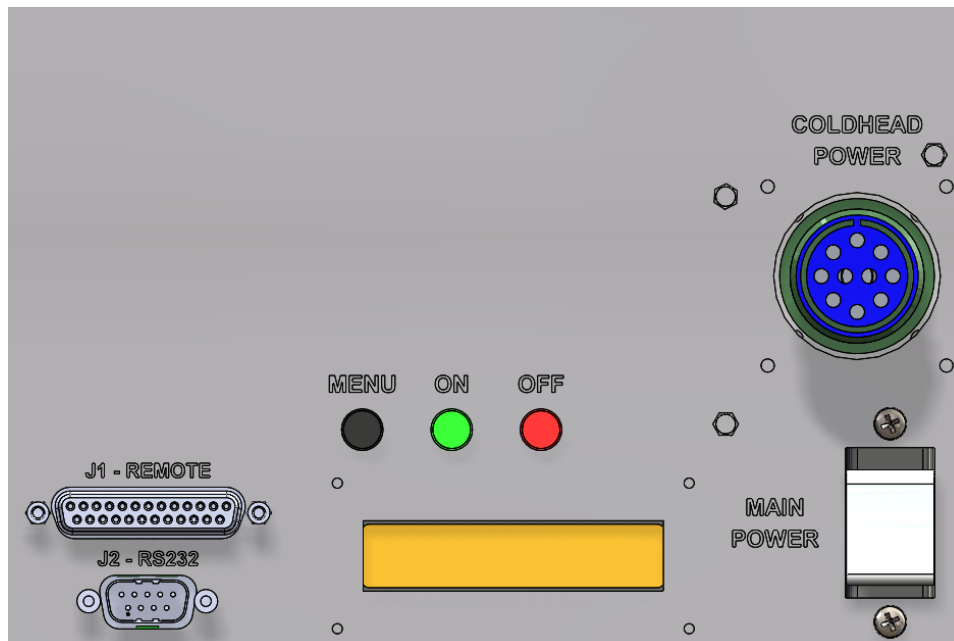

Figure 4 – M700 Low Volt Multi-Drive

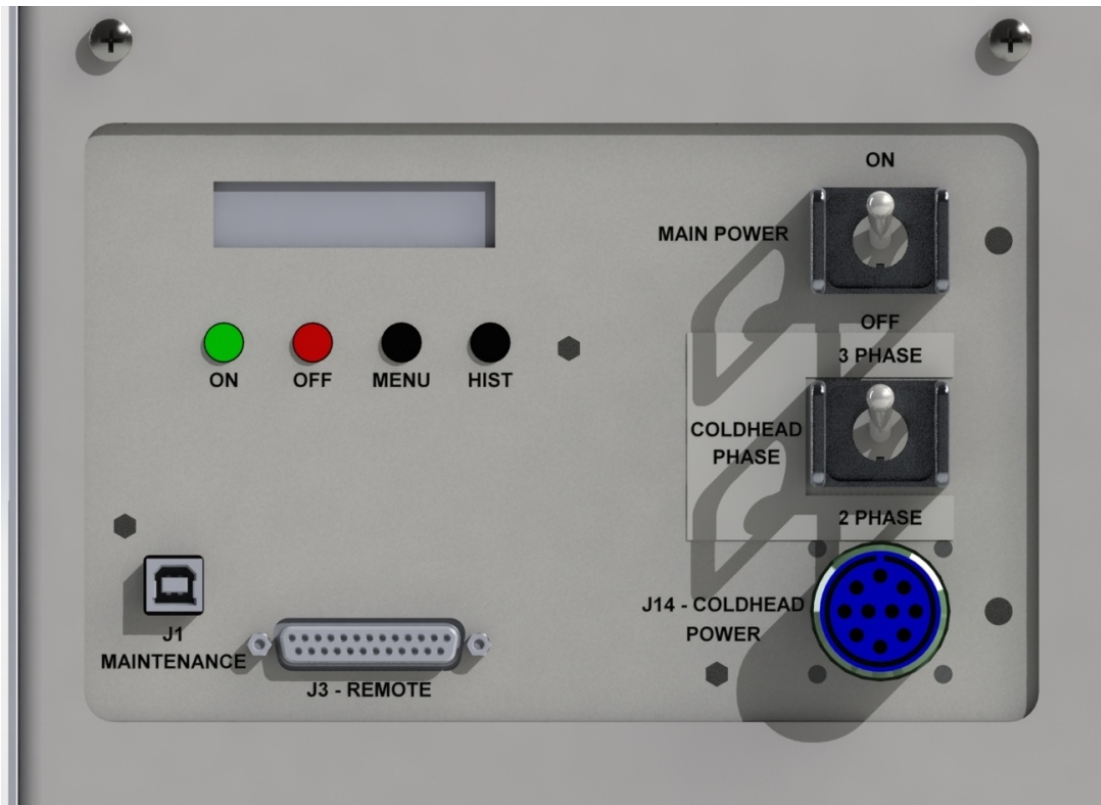
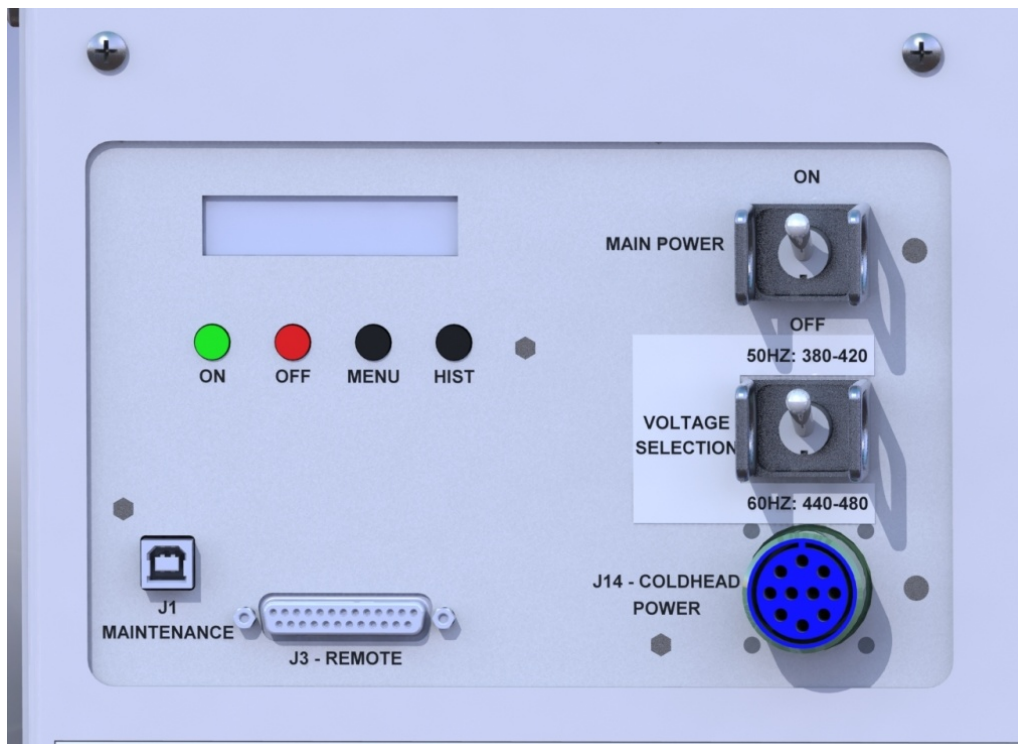

Figure 5 – M700 High Volt Multi-Drive



4.4 Ordering Information

Table 4-5 and Table 4-6 contain ordering information for the Model 700 compressor units and optional accessories.

Table 4-5: Model 700 Water Cooled Helium Compressor Ordering Information

Compressor Configuration	Part Number
COMP, M700, HIGH VOLT, WATER, MULTI-DRIVE	91-00101-000
COMP, M700, LOW VOLT, WATER, MULTI-DRIVE	91-00101-001
COMP, M700, OB, LOW VOLT, WATER (OBSOLETE)	91-00103-001 (OBSOLETE-USE 91-00101-001)

Table 4-6: Optional Accessories and Replacement Parts

Accessories/Replacement Parts	Part Number
Adsorber	80-00005-001
Helium charge line (10ft.*), adapter 1/4" female Aeroquip to 1/4" flare	10346
Helium regulator	HR-580
Helium lines (10ft.*)	10418-10
Helium tee, for connecting two cryopumps	T-MMF
Three-port manifold, for connecting three cryopumps	80075
Splitter box, supplies power to up to three cryopumps	10359
Onboard splitter box, supplies power to up to three Onboard cryopumps	10366
Maintenance manifold, for helium clean-up process on compressors and cryopumps	10134
Cryopump drive cable (10ft.*), sends power to the cryopump motor from the compressor (onboard 10 pin to standard 3 pin)	10355-10
Cryopump drive cable (10ft.*), sends power to the cryopump motor from the compressor	10144-10
Onboard Cryopump drive cable (10ft.*), sends power to the Onboard cryopump motor from the compressor (onboard 10 pin to onboard 10 pin)	10350-10
Tool Kit, Running Purge Decontamination, Swagelok Ends (see Figure 24)	99-00074-000
Tool Kit, Running Purge Decontamination, 1/4" Male Aeroquip Ends (see Figure 25)	99-00074-001
Cable Assy, Remote Patch, 25 Pin Male D-Sub to 14 Pos Female Mil	81-00600-060
Cryopump patch cable (3") (onboard 10 pin to standard 6 pin)	81-00053-002
3/8" Tube to 1/2" FNPT Water Fitting Adapter-Brass	28-00012-002
3/8" Tube to 1/2" FNPT Water Fitting Adapter-Stainless	28-00012-011
Kit, Water Fittings, Metric Adapter	99-00250-000
Shipping Platform and Crate	47-00099-000 47-00100-001

*Custom length available.

5 Installation

5.1 Safety Warnings

Review the safety warnings in Section 3 before beginning any installation activities.



5.2 Installation Steps

5.2.1 Unpacking and Inspection

Once the equipment is received, inspect the exterior of the shipping carton for any signs of damage. Report any damage and file a claim with the shipping company immediately.

In addition, at least two “Tip-n-Tell” or “TiltWatch” labels are mounted on the exterior of the shipping carton. Inspect these labels carefully before accepting the shipment. Any sign that the package has been mishandled during transit may indicate that the compressor may be damaged due to oil migration within the system. This could cause the unit to overheat and ultimately fail after a short period of operation. The compressor must be returned to the factory for service. Report the mishandling of the package and file a damage claim with the shipping company immediately. Failure to do so will void the warranty on the compressor. Please also contact Trillium US Inc. Technical Support using the contact information found in Section 2.2.

Remove the straps and packaging materials from the compressor container, then lift or roll the unit out of the container carefully. Inspect the exterior. If any damage is observed, inform the shipping company and Trillium US Inc. **Keep the original packaging materials in case the unit needs to be returned to the factory for service.**

Most shipping companies have a certain grace period for reporting damages due to shipping in order to process the insurance information in a timely manner. Therefore it is highly recommended that the shipping container be opened and the unit inspected immediately whether or not it will be put into operation right away. Tip and Tells are present on the external packaging as well on the compressor interior.

Caution: When transporting or storing the compressor unit, make certain it is not tilted by more than 10 degrees from horizontal level to avoid potential oil migration damage to the compressor.

5.2.2 Mounting the Compressor

It is highly recommended that the compressor unit be installed on a level and steady surface.

If the unit must be installed in a tilted manner, the maximum tilting angle is 10 degrees. Tilting the unit more than this maximum allowable angle could result in damage and contamination in the system, and may void the warranty on the unit.

5.2.3 Preparing the Compressor for Operation

1. Check the voltage of the power source before connecting the main power cable to a suitable connector or disconnect box, making sure that the compressor switch is off.
 - a. If the voltage of the power source is different from the factory default setting (see **Table 4-2**) it may be necessary to change the tap settings on the 24VAC control transformer located inside the electrical box of the compressor for configurations of the electrical box shown in **Figure 2** and **Figure 3**. Follow the steps described in Section 5.2.5 to make the change.
2. Cooling water connection:
 - a. Typical municipal drinking water is acceptable, however, a closed loop chilled water source is recommended. Trillium US Inc. recommends that an inline water filter be used on the water supply line to filter out any contaminants before they enter the compressor heat exchanger circuit.
 - b. Minimum water flow rate of 1.6 GPM (6 LPM) is required to achieve a maximum discharge temperature of 100°F (38°C). Ideal discharge temperature is 90°F (32°C). A flow rate of 1.8~2.0 GPM (6.8~7.6 LPM) is recommended. The inlet water temperature should not exceed 80°F (27°C). See **Figure 1** water flow rate curve.
3. Verify that helium pressure is set according to **Table 4-4**. If the pressure is low, refer to Section 5.2.4.2 for charging procedures.
4. Visually inspect the water flow meter for discoloration or sediments, as this would indicate that the water supply may be contaminated.
5. The compressor is now ready to be connected to the cryopump(s) or coldhead(s).



5.2.4 Installation

5.2.4.1 Ambient Conditions and Coolant Connection

Ambient Conditions:

When the compressor is in operation, the ambient temperature should be between 40°F - 104°F (5°C - 40°C). The compressor unit should be set up in a non-condensing environment. There shall be at least 250mm (9.85") of vacant space on either side of the compressor and 400mm (15.75") of vacant space above the compressor to allow for free flow of ambient air. An optimal location would be in a well ventilated (or temperature controlled) location.

Coolant Connection:

Caution: For water-cooled compressor models, the water used in the unit operation must meet the specifications indicated in Section 4.2.

Caution: Failure to comply with the coolant specifications may result in serious damage to the compressor and may void the warranty on the unit.

Identify the inlet and outlet connection ports first before connecting the hoses. The water supply line should be connected to the inlet port on the compressor.

An in-line water particulate filter is recommended to prevent heat exchanger contamination.

Periodically check the coolant flow rate and temperature to ensure the proper operation of the compressor unit.

5.2.4.2 Verifying and/or Refilling Compressor with Helium Gas

Caution: All safety regulations related to handling pressurized gas cylinders must be observed. Only use helium with 99.999% or better purity (He 5.0 UH) when performing refill operation.

The compressor should already be pressurized to 200 ± 10 PSIG (13.8 ± .7 Bar) upon arrival. However, in the event that the static pressure is too low or too high, steps shall be taken to restore the compressor to the proper helium pressure levels. Examples of situations when the compressor may have lost some pressure include lost pressure due to connecting/disconnecting helium flex lines, or after certain maintenance/clean-up procedure.

Therefore, prior to each operation of the compressor, verify that the helium pressure inside the compressor is at the proper levels as stated in **Table 4-3**. If the pressure is outside of the required limits, follow the appropriate steps below:

Pressure should also be checked after the compressor has been connected to the overall system (as instructed in Section **5.2.4.3**), as the static pressure may change based on the overall system pressure after connection.

If the helium pressure is too high:

1. Remove the protective cap from the "Fill/Vent" fitting.
2. Slowly connect the female charge fitting. As the connector is tightened, helium pressure will bleed out of the compressor.
3. Continue to bleed out helium gas until the pressure reaches the desired limits defined in **Table 4-3**. Once the pressure is reached, disconnect the Aeroquip.
4. Re-install the protective cap.

If the helium pressure is too low:

1. Connect a pressure regulator rated at 400 PSIG (27.6 Bar) delivery pressure and a helium charge line to a user-supplied helium supply gas cylinder. Terminate the charge line with the female charge fitting.
2. Set the helium pressure regulator to 10-25 PSIG (.69 - 1.7 Bar). Loosen the ¼" flare connector (part of the female charge fitting, in between the helium charge line and the ¼" female Aeroquip adaptor).
3. Allow helium gas to flow through the flex line for a minimum 30 seconds to purge the charge line of air. Tighten the flare connector while venting. After tightening, close the valve on the pressure regulator.



4. Remove the Aeroquip cap of the helium fill/vent fitting on the front of the compressor.
5. Tighten female charge fitting on the end of the helium charge line to the gas fill/vent Aeroquip fitting of the compressor.
6. Set the pressure regulator to approximately 270 PSIG (18.6 Bar) and slowly open the valve on the pressure regulator. When the helium supply pressure gauge reaches the specified limits found in **Table 4-4**, tightly close the regulator valve.
7. Ensure the regulator valve is tightly closed. Shut off the helium pressure regulator on the helium bottle.
8. Remove the female charge fitting and reinstall the Aeroquip cap onto the compressor.

Caution: If the compressor pressure drops over a period of time, either when not in operation or without the lines being connected/disconnected, this may be an indication that there is a leak along the helium circuit (i.e. compressor, lines or coldhead/cryopump). If that is the case, do not just keep refilling the system with helium gas. Such leaks will introduce ambient air/moisture and cause contamination in the helium stream. This will result in catastrophic failure of the whole cryogenic system if not properly addressed. Contact and report the leak to Trillium US Inc. immediately using the contact information found in Section 2.2.

5.2.4.3 Connecting the Helium Flex Lines

Caution: Connect or disconnect the helium flex lines only when the power to the compressor unit is switched off. Never twist or kink the helium flex lines during the installation process.

Before connecting the helium flex lines, follow these steps:

1. Identify the helium "Return" (low pressure) and "Supply" (high pressure) ports on the compressor front panel.
2. Clearly mark the helium flex line that will be used to connect to the corresponding "Supply" and "Return" port on the cryopump or coldhead.

Note: The helium flex lines are equipped with self-sealing couplings which can be connected or disconnected without helium escaping.

Follow these steps to connect the helium flex lines:

1. Unscrew the protective caps from the couplings and keep the caps for future use.
2. Check the couplings for cleanness. When necessary, use lint-free clean cloth or soft brush to clean the couplings.
3. Check the self-sealing connector flat rubber gasket to make sure that it is clean and properly positioned. Replace any missing or defective seals.
4. Use only the open-wrenches supplied with the installation kit or equivalent wrenches. For a ½" coupling, tighten with a 1-3/16" wrench and stabilize with a 1" wrench.
5. Make the initial turns by hand and then use the wrenches until the fittings bottom out. **This is critical, improper or loose connections will affect compressor function.**
 - a. Effective connections can be validated by confirming the leak rate is less than 1×10^{-5} mBar -l/sec)

If the flex lines need to be bent to a radius less than 8" (20 cm), then a 90° helium elbow needs to be installed. Contact Trillium US Inc. using the contact information found in Section 2.2.

Some installations may require different accessories to be installed in line with the helium flex lines. To connect these accessories, follow the instructions listed above and any other applicable user manual associated with the accessory.

5.2.5 Electrical Connection

Caution: Before connecting power to the compressor unit, make sure the factory setting of the operating voltage matches that of the power supply where the unit is being installed. Failure to do so will result in performance degradation of the system.

If the voltage of the power source is different from the factory default setting (see **Table 4-2**), it may be necessary to change the tap settings on the 24VAC control transformer located inside the electrical box of the compressor if configured with electrical boxes shown in **Figure 2** and **Figure 3**. Follow the steps described below to make the change:

1. Unscrew the top (wrap-around) cover of the unit
2. Unscrew the electrical box cover
3. Change taps on the 24VAC control transformer to the setting that is closest to that of the power source (illustrated in **Figure 6**)
4. Put back and screw down the electrical box cover
5. Put back and screw down the panels and top cover of the compressor

Electrical connections are to be made in accordance with the schematics shown in **Figure 15** thru **Figure 17** for electrical boxes shown in **Figure 2** and **Figure 3** and in accordance with schematics shown in **Figure 18** and **Figure 19** for electrical boxes shown in **Figure 4** and **Figure 5**.

Figure 6 – M700 Helium Compressor Control Voltage Transformer Tap Settings



6 Operation

6.1 Before Switching ON the System

After the compressor unit and its load (cryopump, coldhead, etc) are installed and connected, check the helium gas pressure as indicated by the pressure gauges mounted on the front panel of the compressor unit. Refer to Section 4.2 for the proper static pressure readings for the compressor.

An LCD screen is located on the front panel display of the compressor. The LCD screen will display all system information, including the reason for any unexpected compressor shut down (temperature fault, pressure fault, phase fault, system error, etc.). The screen will also state the condition of the coldhead/cryopump (on or off).

If the helium pressure needs to be adjusted, refer to Section 5.2.4.2 for procedures to adjust the helium pressure inside of the compressor.

6.2 Normal Operation

The load of the compressor can be powered through the power connectors located on the front panel of the compressor. To start operation of the compressor, do the following:

1. Open the water supply line.
2. Switch on the main power source.
3. Press the green ON button to start the compressor. Both the compressor and its load should start simultaneously.
4. Press the OFF button (red) on the front panel to stop the compressor. Allow water to circulate through the compressor for a minimum of 10 minutes before shutting off the water flow.
5. For automated/remote compressor start/stop operation, refer to Section 0.

Note: During initial start-up, the compressor internal relief valve may begin to “Chatter”. This is a normal occurrence and should subside within a few minutes.

During operation, check the operating pressure frequently. Refer to Table 4-3 for required operating pressures. If necessary, stop the compressor and adjust the helium pressure (see Section 5.2.4.2). If pressure drop-off occurs frequently, a substantial leak may be in the helium circuit. In this case, stop operation and contact Trillium US Inc. customer service immediately (see Section 2.2).

Note: During shut down, the compressor motor may reverse rotate as the pressures equalize internally through the scroll members of the motor. This will cause the compressor to emit a “shuttering” sound. This reversal of direction has no effect on the compressor durability and is entirely normal.

6.2.1 Cycle Times

There is no set answer to how often the cryogenic compressor can be started and stopped in an hour. Trillium US Inc. recommends a maximum of twelve cycles per hour.

One critical consideration is a minimum run time required to return oil to the compressor after start up. To assure proper oil return, one minute is the minimum run time for all cryogenic compressors. A second consideration is a four minute minimum off cycle time once the compressor cycles off.

6.3 Electronics Interface Connections

The Model M700 helium compressors are provided with a pig tail for connecting to the installation location.

Electrical box interfaces are described below.



6.3.1 Remote Interface

The electrical box can be controlled through a remote interface. This allows a PLC or other hardware device to control and monitor certain functions of the compressor and cold-head. A D-sub 25 pin connector is provided for remote interface control and status collection; the pin-out is shown in **Table 6-1**.

Table 6-1: J1 or J3 Remote Connector (25-Pin D-Sub)

PIN #	SIGNAL DESCRIPTION
1	N/C
2	N/C
3	Reset
4	Cold Head ON/OFF
5	N/C
6	Compressor ON/OFF
7	N/C
8	N/C
9	N/C
10	N/C
11	N/C
12	N/C
13	N/C
14	N/C
15	N/C
16	Pressure Alarm
17	Phase Error
18	Temperature Alarm
19	Run Status
20	N/C
21	N/C
22	N/C
23	N/C
24	Ground
25	+24V Output

6.3.2 D-Sub User Controls

The Model M700 compressors that have electrical box configurations as shown in **Figure 2** and **Figure 3** remote input control signals (pins 3, 4, 6) require a user slide switch or opto-coupler as shown in **Figure 7**. Independent control of the compressor and cold head / cryo pump is not possible with this configuration of electrical box. The compressor is shipped with a mating plug which when left installed will cause the compressor to return to powered on state in the event of a power failure.

Example: To start the compressor connect pin 6 to pin 24. To start the coldhead, connect pin 4 to pin 24. For simultaneous operation of the compressor and coldhead, jumper pin 6 to pin 4.



Figure 7 – User Control Signal Interface

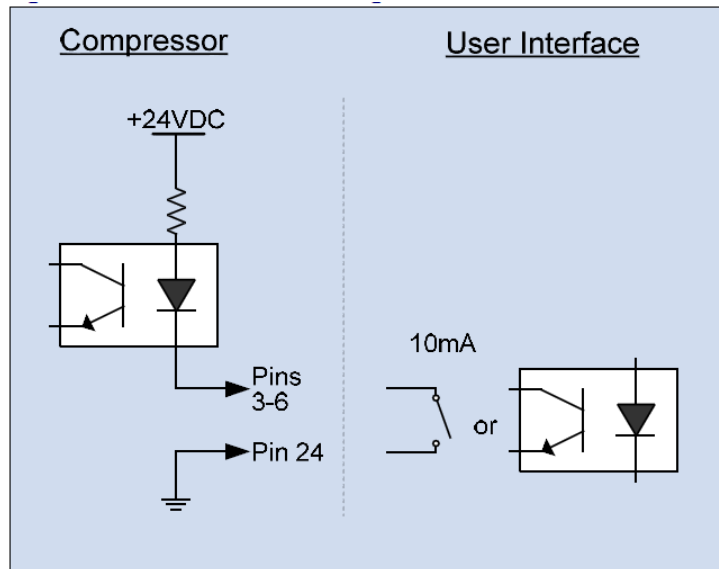

For the Model 700 compressors that have electrical box configurations as shown in **Figure 4** and **Figure 5** remote interface inputs are shown in **Table 6-2**. The inputs require a dry-contact switch or an opto-coupler as shown in **Figure 7**. Short each input (pin 3, 4, or 6) to the Input Return (pin 24) to assert the signal. Open the circuit to de-assert the signal.

Since there are up to three ways to issue commands in the **Figure 4** and **Figure 5** electrical boxes; front panel buttons, USB interface, and the DB25 interface, the control logic uses a “last command” approach based on state transitions. The transition of shorting an input to pin 24 signals the controller to turn on the corresponding subsystem. The transition of removing the short to pin 24 signals the controller to turn off the subsystem. If the remote system intends to turn on a subsystem and the input is already shorted to pin 24, then the short must be removed for 100ms or more and then the short reapplied. If the remote system wants to turn off a subsystem and the input is already open, the pin must be shorted to pin 24 for 100ms or more and then opened again.

Table 6-2: Remote Interface Inputs for Electrical Boxes Shown in Figure 4 and Figure 5

SIGNAL	SIGNAL DESCRIPTION
Reset	Short pin 3 to pin 24 for 3 seconds or longer to reset the control board processor. Leave pin 3 open-circuit (floating) for normal operation.
Coldhead Enable	Short pin 4 to pin 24 to turn on the coldhead. Open-circuit pin 4 to turn off the coldhead.
Compressor Enable	Short pin 6 to pin 24 to turn on the compressor. Open-circuit pin 6 to turn off the compressor.

6.3.3 D-Sub User Status

The Model M700 compressors that have electrical box configurations as shown in **Figure 2** and **Figure 3** remote output status signals (pins 16-19) are designed to drive a user side opto-coupler as shown in **Figure 8**.

Example: Use the output voltage from pin 19 & 25 to monitor the run status of the compressor, this output can be used to drive a LED or used as an input to a PLC.

Figure 8 – User Status Signal Interface

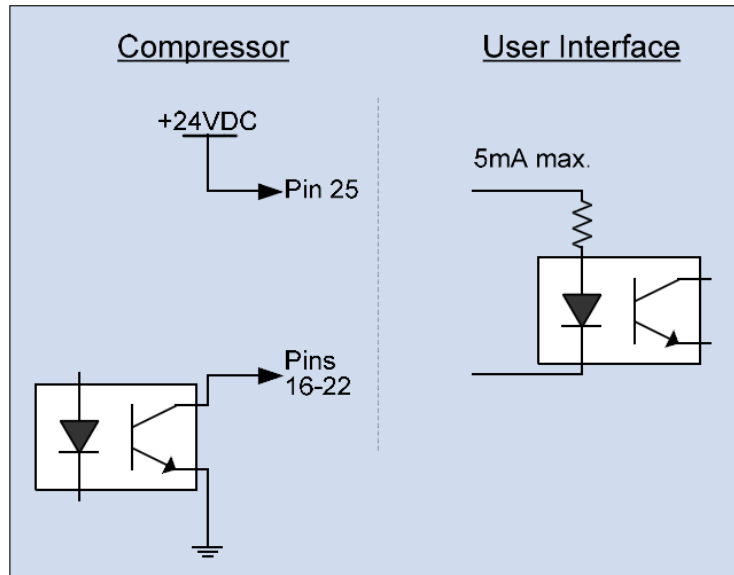

For the Model 700 compressors that have electrical box configurations as shown in **Figure 4** and **Figure 5** remote interface outputs are shown **Table 6-3**. The output signals are designed to drive a user-side opto-coupler as shown in the figure above. Each output is shorted to ground by the controller when the output is asserted and is open-circuit otherwise. Connect a 24VDC load between each output pin and the Output Source (+24V power) at pin 25. Each output should draw a maximum of 5 milliamps. The outputs can be used to drive LEDs or opto-couplers.

Table 6-3: Remote Interface Outputs for Electrical Boxes Shown in Figure 4 and Figure 5

SIGNAL	SIGNAL DESCRIPTION
Pressure Alarm	When the compressor pressure is too low, pin 16 is shorted to ground. Pin 16 is left floating when the pressure is normal or the system is off.
Phase Error	When there is input power phase error, pin 17 is shorted to ground. Pin 17 is left floating when there is not a phase error.
Temperature Alarm	When the compressor is too hot, pin 18 is shorted to ground. Pin 18 is left floating when the compressor temperature is normal.
Run Status	When the compressor, the coldhead, or both are running, pin 19 is shorted to ground. When the compressor and coldhead are both off, pin 19 is left floating.

6.3.4 Compressor Front Panel User Interface

For the model 700 compressors that have electrical box configurations as shown in **Figure 2** and **Figure 3**, on start-up, the front panel LCD will display the title screen and revision information. Once initialization is complete, the main screen is displayed.

Note: If the phases are not connected properly, a "Phase Error" will be displayed. The compressor cannot be started until the unit is powered down and the phase error is corrected.

These configurations of the compressor provide 3 buttons and a 2-line display for easy operation:

- Off
- On
- Menu

Pressing the “Off” button from any screen results in powering the compressor off. The unit can only be turned on if all operational checks are passed. If a system error occurs, pressing the “Menu” button displays the status of each system check. If all operational checks are successful, pressing the “Menu” button displays the operating hours on the compressor.

The “On” button powers the compressor if all system checks are successful. If a system check is in the failed state, the “On” button is ignored.

6.3.4.1 Compressor Front Panel User Interface Revised

For the Model 700 compressors that have digital electrical box configurations as shown in **Figure 4** and **Figure 5**, on start-up, the front panel LCD will display its initialization sequence and once complete the system status screen will be displayed showing the current state of the compressor and cold head as well as the current accumulated compressor run time.

Note: If the phases are not connected properly, an "AC Power Phase Error" will be displayed. The compressor cannot be started until the unit is powered down and the phase error is corrected.

These configurations of the compressor provide 4 buttons and a 2-line display for easy operation:

- **Off:** Pressing this button will turn the Cold Head, Compressor, and Solenoid Valves off. Pressing the Off button will always override the signals on the Remote Interface allowing the user to turn off the system.
- **On:** Pressing this button will turn the Solenoid Valves, Compressor, and Cold Head on unless prohibited by one or more fault interlocks.
- **Menu:** Pressing this button will cycle between the Status Screen and the Active Faults Screen. Pressing this button when the Fault History screen is displayed will move to the Status Screen. If more than one fault is active, the Menu button is used to cycle through each of the active faults before going back to the Status Screen.
- **History:** From either the Status Screen or Active Faults Screen, pressing this button will take the user to the Fault History screen where the most recent fault will be displayed. Pressing the History button will cycle through each of the logged faults in reverse-chronological order until the last logged fault is displayed. Then the fault history will wrap around to the most recent fault again.

6.3.5 Compressor Operational Checks

Table 6-4 lists all of the compressor operational checks and the cause of a failed operational check.

Table 6-4: Model 700 Optional Checks

System Interlock	Fault
Helium Pressure Alarm	Pressure alarm contact is not CLOSED. Verify pressure contact and helium pressure.
Helium Temperature Alarm	Temperature alarm contact is not CLOSED. Verify temperature contact and helium temperature.
Oil Temperature Alarm	Temperature alarm contact is not CLOSED. Verify temperature contact and oil temperature.
Overload Alarm	Contactors overload tripped. Reset overload on contactors.

6.3.5.1 Compressor Front Panel Fault Errors

For the Model 700 compressors that have digital electrical box configurations as shown **Figure 4** and **Figure 5** the following errors can be displayed:

- System Error
- Compressor Overload
- Low Pressure
- High Temperature
- AC Power Phase Error
- F13-F15 Fuse Blown



- F16-F18 Fuse Blown
- F21-F23 Fuse Blown
- 3PH Detected in 1PH Mode
- 1PH Detected in 3PH Mode

6.3.6 Compressor Maintenance Warning

For the Model 700 compressors that have digital electrical box configurations as shown in **Figure 4** and **Figure 5**, the front panel LCD will display “Change Adsorber” at an elapsed time of 15,000 hours (since last reset). Temporary access to alternate screens can be gained via the Menu button. Once the adsorber has been replaced the maintenance timer can be reset by pressing and holding the Menu and History buttons together for 5 seconds.

6.3.7 Compressor System Shutdown

Manual shut-down

Push the OFF button

Automatic shut-down

The following system indication will cause the compressor to automatically shut down:

1. Low Helium pressure
2. High Helium pressure
3. High Helium temperature
4. High Oil Return temperature
5. Contactor Overload
6. Loss of Power

If an automatic shut down occurs, refer to **Table 6-4** to identify and remove the fault. Once the fault has been corrected, the user can restart the system by pressing the “ON” button.

6.3.8 Compressor Interfaces

For the model M700 compressors a connector is provided for serial communication.

6.3.8.1 Serial Port Interface (J2-RS232)

For the model M700 compressors that have electrical box configurations as shown in **Figure 2** and **Figure 3** a DB9 male connector is provided for serial port communications. A “straight through” serial cable, as shown in **Table 6-5** and **Table 6-6**, is necessary for interfacing to the serial port. Only pins 2, 3, and 5 are required.

Table 6-5: Serial Port Interface Pin Assignments

DB9 Female (to Compressor)		DB9 (to Controller)
1	-----	1
2(TxD)	-----	2(TxD)
3(RxD)	-----	3(RxD)
4	-----	4
5(Gnd)	-----	5(Gnd)
6	-----	6
7	-----	7
8	-----	8
9	-----	9



Table 6-6: Serial Port Cable

Serial Port Settings	
Baud Rate	4800
Data Bits	8
Parity	NONE
Start Bits	1
Stop Bits	NONE

6.3.8.2 USB Interface (J1-Maintenance)

For the Model 700 compressors that have digital electrical box configurations as shown in **Figure 4** and **Figure 5** a USB type B connector is provided. This connector provides control input and status output using USB protocol. The underlying protocol of the USB link is HID. The data is streamed as raw bytes.

6.3.9 Serial Communications via R232

- No handshaking
- PC is always the host.
- Commands and data requests from host.
- Message Format:
 - Byte 1: STX (02h = control-B)
 - Bytes 2..4 Command or data request
 - Bytes 5..X Command or requested data
 - Byte X+1 (Carriage Return = 0Dh)
- All bytes are ASCII type (20h..7Fh)
- Maximum value for X is 126.
- Individual data values are separated by a forward slash
- Used letters are ASCII capitals.
- Used numbers are ASCII decimals.
- Incorrect formats are ignored

6.3.9.1 Serial Port Commands

Serial port commands are provided in **Table 6-7** thru **Table 6-10**.

Table 6-7: Serial Port Commands

Command	No. of Bytes	Description
Send: STX SYS1 CR	1 + 4 + 1	Turn System On
Receive: STX SYS2 CR	1 + 4 + 1	System Error

Table 6-8: Data Message

Command	No. of Bytes	Description
Send: STX DAT CR	1 + 3 + 1	Data request
Receive: STX DAT	1 + 3	
0.00	4 + 1	SW Version
000000	6 + 1	Reserved
12345	5 + 1	Hours Counter
0000000000000000	15	Reserved
003	3 + 1	On Timer(seconds)

Command	No. of Bytes	Description
1	1 + 1	Status:
1	1 + 1	0 = Off 1 = On 2 = System Error
0000	4	Compressor Status: 0 = Off
00	2 + 1	
1000000000000000	16 + 1	
4	1	1 = On
CR		Reserved Number of active errors 1 = active error 0 = error inactive Number of errors logged (≤ 8) End of message

Table 6-9: Command/Data

Send	Compressor	Description
STX SYS x CR	STX SYS y CR	X = Y = 0 Off X = Y = 1 On Y = 2 System Error
STX SC x y CR	STX SC x y CR	X = 1 Cold Head Y = 1 On Y = 0 Off
STX DAT CR	As described in previous table	Data Requested
STX ERR CR	STX ERR xx hhhh / xx hhhh / xx hhhh CR (Will display last 8 error codes)	xx = error code hhhhh = hours counter

* Example:

STX SYS1 CR Turns the compressor on, the system will respond with SYS1
STX SYS0 turns the compressor off

STX 11 CR = Coldhead On the compressor will return SC11
Note the compressor must be running to turn the Coldhead on.

Table 6-10: Error Codes

Error Code	Display	Description
1	System Error	Error has occurred
2 - 3		Reserved
4	Contactactor Error	Compressor overload relay has tripped off.
5	Phase/Fuse Error	Line voltage out of Phase. Fuses blown
6	Pressure Alarm	Low pressure switch tripped
7	Temperature Fail	Thermal Switch has tripped

Error Code	Display	Description
		Coolant Supply Failure Lack of cooling
8 - 16		Reserved

6.3.10 Communications via USB

Communication via USB can be achieved via PC integration. The format for the packet is shown in **Table 6-11**.

Table 6-11: USB Packet format

Field	Bytes	Range	Notes
Header #1	1	0x55	
Header #2	1	0xAA	
Packet Length	2	[0:102]	Number of bytes in: <ul style="list-style-type: none"> • Source • Destination • Command • Payload Data Field is transmitted in <i>little endian</i> .
Command	1	[0:255]	See Table 6-12
Payload Data	Various	Various	See Table 6-13 thru Table 6-25 Payload fields that are native types (e.g. integers) and have more than one byte are sent in <i>little endian</i> .
CRC	1	[0:255]	The packet's CRC is calculated by: <ul style="list-style-type: none"> • Seed value = 0 • Polynomial = $x^8 + x^2 + x + 1$ • Includes the following fields: <ul style="list-style-type: none"> ○ Payload Data Length ○ Source ○ Destination ○ Command ○ Payload Data

Table 6-12: USB Maintenance Interface Command ID's

Name	Packet ID	Description
Get Status	229	Requests the system status
Status Response	10	Packet contains system status information
Get Fault History	53	Requests the set of historic faults
Fault History Response	54	List of either current or historic faults
Set Compressor	57	Commands the compressor to be on/off
Set Coldhead	58	Commands the cold/head to be on/off
Reset	224	Forces the control board processor to reset
Get Version	226	Request for the firmware version information

Name	Packet ID	Description
Version Response	225	Packet contains the version, build date, and part number
ACK	254	Response to indicate a command was executed successfully
NACK	255	Response to indicate a command failed to execute successfully

6.3.10.1 USB Payload Formats

Table 6-13 thru **Table 6-25** define the payload formats for all commands listed in **Table 6-12**.

Table 6-13: ACK Payload Format

Response to: Any command that successfully executes and does not have a specific response.		
Field	Bytes	Range/Units
Response to Command ID	1	See Table 6-12
Payload Length	1	

Table 6-14: NACK Payload Format

Response to: Any command that fails to execute correctly or whose format is incorrect.		
Field	Bytes	Range/Units
Command ID	1	See Table 6-12
Reason Code	1	See Table 6-15
Payload Length	2	

Table 6-15: NACK Reason Codes

Value	Description
0	Unspecified/Other
1	Unrecognized/unsupported command
2	CRC error
3	Parameter out of range or other invalid data
4	Not ready for command
5	Packet length error
6	Timeout

Table 6-16: Get Status Payload Format

Response Expected: Status Response		
Action: Queries the Pump Controller for its current status.		
Field	Bytes	Range/Units
Payload Length	0	No payload data

Table 6-17: Status Response Payload Format

In Response To: Get Status		
Action: Payload contains the Pump Controller status..		
Field	Bytes	Range/Units
Compressor Run Time	4	Seconds
PCB Temperature	2	0.1 C
24V Input Voltage	2	mV
Digital Output States	2	Bit Set: Bit 0 – Compressor Pressure Fault Bit 1 – Compressor Temperature Fault Bit 2 – Phase Error Fault Bit 3 – System Running Bit 4 – Fan/Heater On Bit 5 – Compressor/Solenoid On Bit 6 – Coldhead On Bit 7 – Spare Output #1 On Bit 8 – Spare Output #2 On Bit 9-15 - Reserved
Digital Input States	2	Bit Set: Bit 0 – Coldhead Enable Bit 1 – Compressor/Solenoid Enable Bit 2- System Reset Bit 3 – Compressor Pressure Fault Bit 4 – Compressor Temperature Fault Bit 5 – Compressor Overload Fault Bit 6 – Spare Remote Input #1 Bit 7 – Spare Remote Input #2 Bit 8 – Spare Chassis Input #1 Bit 9-15 - Reserved
Button States	2	Bit Set: Bit 0 – On Button Pressed Bit 1 – Off Button Pressed Bit 2 – Menu Button Pressed Bit 3 – History Button Pressed Bit 4-15 – Reserved
Fault States	2	Bit Set: Bit 0 – System Fault Bit 1 – AC 220V Fuse Blown Bit 2 – AC 24V Fuse Blown Bit 3 – Compressor Overload Fault Bit 4 – AC Phase Fault Bit 5 – Compressor Pressure Fault Bit 6 – Compressor Temperature Fault Bit 7 – 3 Phases Detected; 1 Phase Expected Bit 8 – 1 Phase Detected; 3 Phases Expected Bit 9-15 - Reserved
Payload Length	16	

Table 6-18: Get Fault History Payload Format

Response Expected: Fault History Response		
Action: Queries the Pump Controller for the list of historic faults.		
Field	Bytes	Range/Units
Payload Length	0	No payload data

Table 6-19: Fault History Response Payload Format

In Response To: Get Fault History		
Action: Payload contains the list of historic faults.		
Field	Bytes	Range/Units
Number of Faults	1	[0..25]
Reserved	1	N/A
<i>The remaining payload is a sequence of <u>Number of Fault</u> entries:</i>		
Fault Identifier	1	See Table 6-20
Timestamp	4	Running time, in seconds, of the compressor at which the fault occurred.
Payload Length	[2..102]	

Table 6-20: Fault Codes

Value	Description
0	System Fault
1	AC 220V Fuse Blown
2	AC 24V Fuse Blown
3	Compressor Overload
4	AC Phase Fault
5	Compressor Pressure Fault
6	Compressor Temperature Fault
7	3 Phases detected; 1 Phase expected
8	1 Phase detected; 3 Phases expected

Table 6-21: Set Compressor Payload Format

Response Expected: ACK/NACK		
Action: Powers the Compressor/Solenoid on or off.		
Field	Bytes	Range/Units
Power State	1	0 – Off 1 - On
Payload Length	1	No payload data

Table 6-22: Set Coldhead Payload Format

Response Expected: ACK/NACK		
Action: Powers the Coldhead on or off.		
Field	Bytes	Range/Units
Power State	1	0 – Off 1 - On
Payload Length	1	No payload data

Table 6-23: Reset Payload Format

Response Expected: ACK/NACK		
Action: Performs a reset on the control board processor.		
Field	Bytes	Range/Units
Payload Length	1	No payload data

Table 6-24: Get Version Payload Format

Response Expected: Version Response		
Action: Queries the control board for the set of firmware version numbers.		
Field	Bytes	Range/Units
Payload Length	0	No payload data

Table 6-25: Version Response Payload Format

In Response To: Get Version		
Action: Payload contains the list of firmware version numbers.		
Field	Bytes	Range/Units
Communication Protocol Version	2	[1..255]; currently set to 1
Year code was compiled	2	Full year (yyyy)
Month code was compiled	1	Month (1=Jan; 12=Dec)
Day code was compiled	1	Day of Month
Firmware Part Number	2	Will be 437.
Firmware Version Number	2	
Bootloader Part Number	2	Will be 436.
Bootloader Version Number	2	
Hardware Part Number	2	Will be 401.
Calculated Checksum	2	Should be equivalent to Stored Checksum
Stored Checksum	2	Should be equivalent to Calculated Checksum
Reserved	5	
Payload Length	25	

7 Troubleshooting

7.1 Troubleshooting Activities

Table 7-1 describes some problems that users might encounter while operating the Model M700 Helium Compressor and provides potential solutions to those problems. Additional Fault trees are presented in **Figure 20** and **Figure 21**.

For the Model 700 compressors that have electrical box configurations as shown in **Figure 2** and **Figure 3**, **Table 7-2** lists the fuse function and amperage rating. See **Figure 22** for PCBA fuse locations.

For the Model 700 compressors that have electrical box configurations as shown in **Figure 4** and **Figure 5**, **Table 7-3** lists the fuse function and amperage rating. See **Figure 23** for PCBA fuse locations.

If a compressor problem still persists after performing the corrective actions described in this section, please contact Trillium US Inc. Technical Support for further assistance (see Section 2.2).

Table 7-1: Trouble Shooting Procedures

Problem	Possible Cause	Corrective Action
The compressor On/Off switch is in the On position but will not start.	<ol style="list-style-type: none"> 1. No power is coming from the power source. 2. Incorrect or disconnected wiring within the compressor 3. Thermal protection switch (TS1 and/or TS2) is open. 4. Pressure protection switch (PS1 or PS 2) is open 5. High current has tripped the current overload relay. 	<ol style="list-style-type: none"> 1. Check service fuses, circuit breakers, and wiring associated with the power source. Repair as needed. 2. Check the compressor wiring against the wiring schematic. 3. Confirm that switch TS1 and/or TS2 is open. 4. Add Helium if the pressure is low, remove Helium if the pressure is high 5. Reset the current overload relay.
Compressor stops after several minutes of operation and remains off.	<ol style="list-style-type: none"> 1. High temperature of the compressor caused by insufficient cooling (most likely due to the ambient temperature being too high, resulting in the opening of thermal protection switches (TS1 and/or TS2). 2. Insufficient helium static pressure. 3. High temperature helium gas tripped the thermal protection switch (TS1). 4. Low power source voltage. 5. Mechanical seizure. 6. High Pressure in the system 	<ol style="list-style-type: none"> 1. Confirm that sufficient cooling air is flowing to the compressor. If possible, provide additional cooling to the surrounding environment. 2. Add helium, using the procedures described in Section 5.2.4.2. 3. Check for proper cooling of the compressor unit. 4. Confirm that power source voltage is correct. 5. Contact Trillium US Inc. for assistance. 6. Check for proper pressure in Table 4-4.

Table 7-2: Fuse Listing for Electronics Boxes in Figure 2 and Figure 3

Fuse Designator	Function	Amperage	TUI Part Number
PCBA: F12	Fan	4	31-00012-013
PCBA: F11	Fan	4	31-00012-013
PCBA: F5	Contactors	1.5	31-00012-007
PCBA: F1	Solenoids	2	31-00012-009
PCBA: F2	Solenoids	2	31-00012-009
PCBA: F3	Cold head	4	31-00012-013
PCBA: F9	Cold head	4	31-00012-013
PCBA: F4	Cold head	4	31-00012-013
PCBA: F10	PCBA Protection	0.8	31-00012-012
Fuse Box: F6	Scott-T Protection	4	31-00152-009
Fuse Box: F7	Scott-T Protection	4	31-00152-009
Fuse Box: F8	Scott-T Protection	4	31-00152-009
Transformer Mounted: F10*	Control Transformer	5.6	50173-2
Fuse Box: F13**	Control Transformer	0.4	31-00152-001
Fuse Box: F14**	Control Transformer	0.4	31-00152-001
Fuse Box: F15**	Heater	10	31-00152-004
Fuse Box: F16**	Heater	10	31-00152-004
Fuse Box: F17**	Control Transformer	3	31-00152-003

*Standard Unit Only

**On-Board Unit Only

Table 7-3: Fuse Listing for Electronics Boxes in Figure 4 and Figure 5

Fuse Designator	Low Volt Function	Amperage	TUI Part Number	High Volt Function	Amperage	TUI Part Number
PCBA: F13	AC input to PCBA	8	31-00012-014	T2-T3 Output	6	31-00012-016
PCBA: F14	AC input to PCBA	8	31-00012-014	T2-T3 Output	6	31-00012-016
PCBA: F15	AC input to PCBA	8	31-00012-014	T2-T3 Output	6	31-00012-016
PCBA: F16	T1 Output-24VAC	5	31-00012-015	T1 Output-24VAC	5	31-00012-015
PCBA: F18	T1 Output-24VAC	5	31-00012-015	T1 Output-24VAC	5	31-00012-015
PCBA: F21	T2-T3 Input	4	31-00012-013	Cold head motor input	4	31-00012-013
PCBA: F22	T2-T3 Input	4	31-00012-013	Cold head motor input	4	31-00012-013
PCBA: F23	T2-T3 Input	4	31-00012-013	Cold head motor input	4	31-00012-013

Fuse Designator	Low Volt Function	Amperage	TUI Part Number	High Volt Function	Amperage	TUI Part Number
High Volt Fuse Block: F1	N/A	N/A	N/A	T4 Input: Heater Power	5	31-00152-011
High Volt Fuse Block: F2	N/A	N/A	N/A	T4 Input: Heater Power	5	31-00152-011

8 Maintenance

8.1 Maintenance Personnel Requirements

Only trained and qualified personnel should perform the maintenance procedures described in this section. All other maintenance work must be performed by Trillium US Inc. personnel in the factory. Please contact Trillium US Inc. to make arrangement for such work. See contact information in Section 2.2.

8.2 Removing the Compressor from Service: Removal, Transport and Storage

It is recommended that the Model 700 compressor be removed from service when carrying out the maintenance duties described in Section 8.3.

To remove the compressor unit from service, do the following:

1. Turn off the compressor unit by pressing the OFF button
2. Switch off the main power supply to the compressor
3. Separate the compressor unit from the main power source
4. Allow the compressor load (cryopump, coldhead, etc.) to warm up before detaching helium flex lines

Caution: Loosening or detaching helium flex lines with the compressor load at low temperature without proper warming-up can result in loss of helium and/or pressure rise in the cryopump or coldhead unit beyond its designed maximum pressure level.

When transporting the compressor unit, follow these guidelines:

1. Make sure the appropriate protective caps are properly secured before shipping.
2. Always store the compressor unit in a dry place.
3. If a freezing temperature environment is anticipated whether during shipping or under storage, ensure all water in the compressor heat exchanger circuit is properly drained.

Caution: The compressor unit should never be tilted more than 10 degrees either during shipping or in storage.

8.3 Scheduled Preventative Maintenance Activity

The only scheduled field service maintenance required on the Model M700 compressor is the replacement of compressor adsorber after every 15,000 hours of operation or 2 years, whichever comes first.

The adsorber is used as the final filter to keep the oil vapor out of the helium gas just before the gas is pumped into the compressor load (cryopump, coldhead, etc.). After about 15,000 hours of operation or 2 years, the effectiveness of the adsorber will decrease and need to be replaced. If not replaced, the oil particles could accumulate on the cold surface of the compressor load, reducing the cooling performance of the overall system. In severe cases of such oil contamination, the load could cease to function completely.

For the compressors that have digital electrical box configurations as shown in **Figure 4** and **Figure 5** a 15,000 hour resettable maintenance timer is provided; once 15,000 hours has elapsed a “Change Adsorber” message is displayed on the LCD.

To remove and replace the compressor adsorber, follow the steps described in Sections **8.3.1** and **8.3.2**.

8.3.1 Remove the Compressor Adsorber

To remove the compressor adsorber:

1. Turn off the compressor and disconnect it from the main power supply.
2. Remove the top cover and rear panels from the compressor. See **Figure 9**.
3. Allow sufficient time for the compressor load (cryopump, coldhead, etc.) to warm up to room temperature before detaching the helium flex lines from the compressor.
4. Unscrew the connections between the adsorber-to- oil mist (vapor) separator and the adsorber-to-copper hard line. See **Figure 10**. Use caution so that the hard line on the oil mist (vapor) separator does not twist during this operation. See below for general guidelines regarding helium flex line disconnections.
5. Remove the 4 bolts that secure the adsorber to the compressor base. Save the bolts and washers for installation of the new adsorber.
6. Remove the adsorber from the compressor. See **Figure 11**.
7. The removed adsorber can be returned to Trillium US Inc. for credit. Section **2.2** provides the contact information.

Figure 9 – Removal of Top Cover and Rear Panels

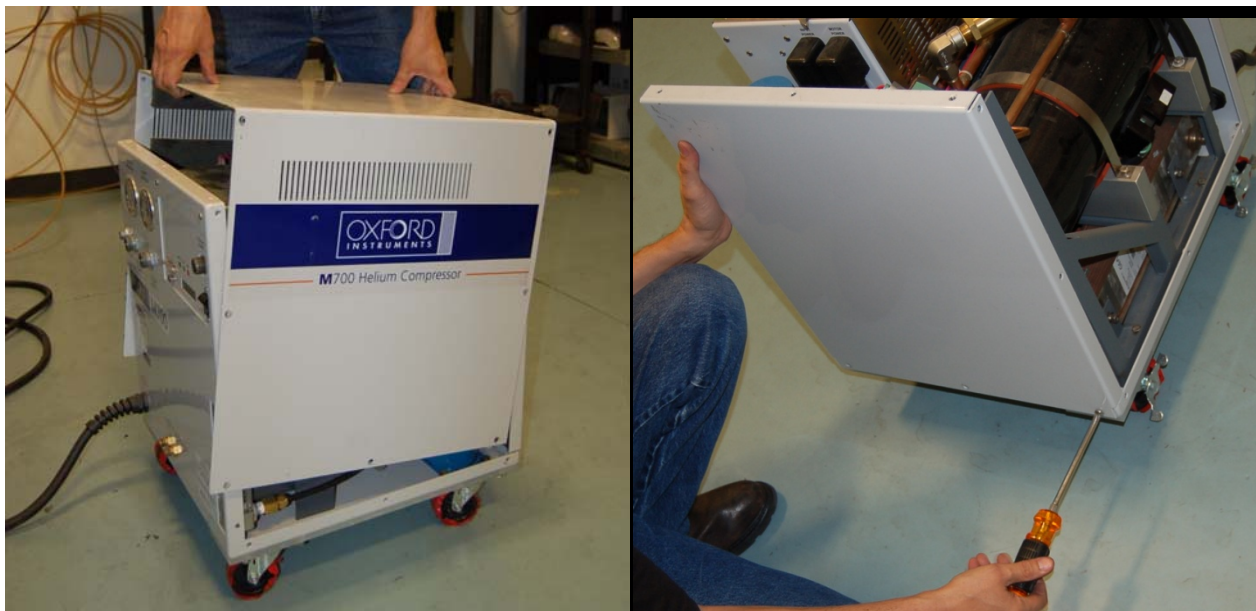

Figure 10 – Adsorber Aeroquip Connection Points

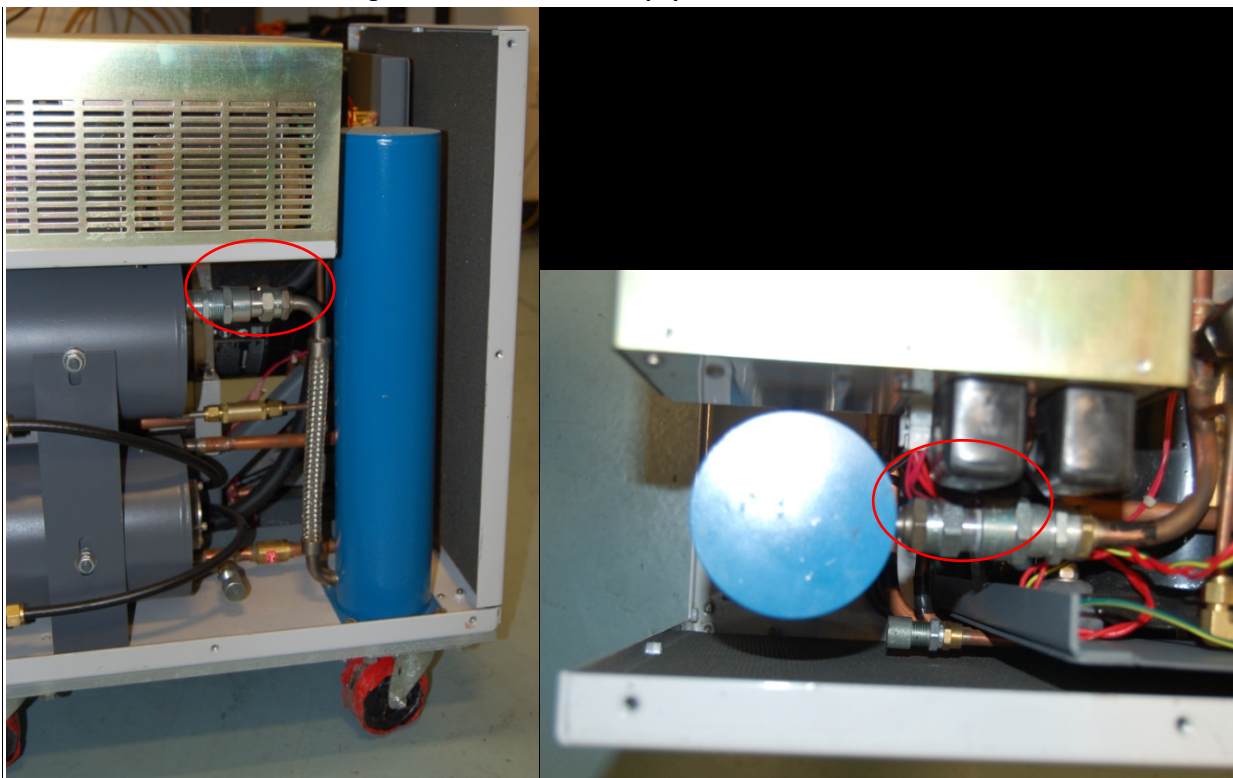
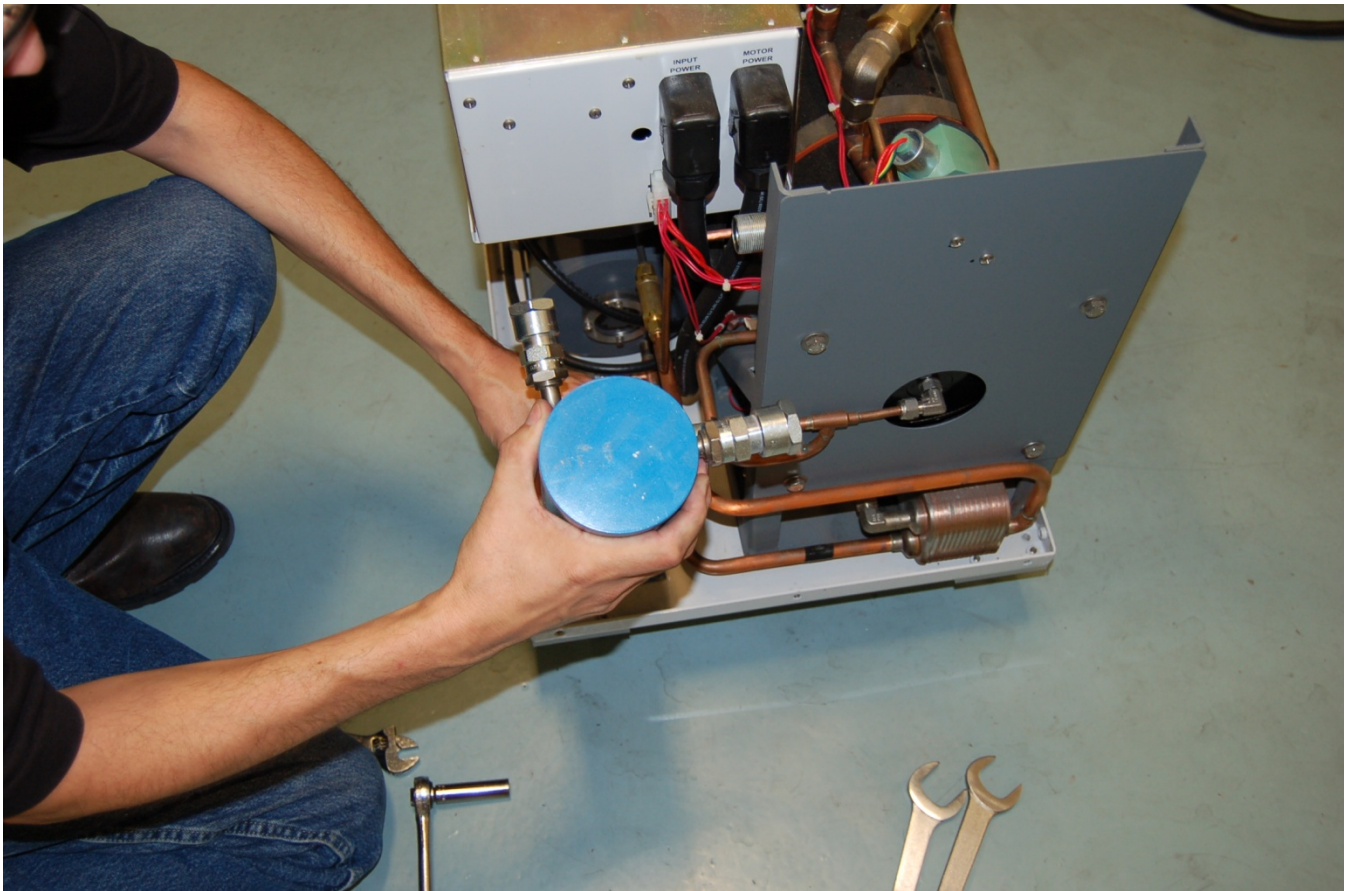
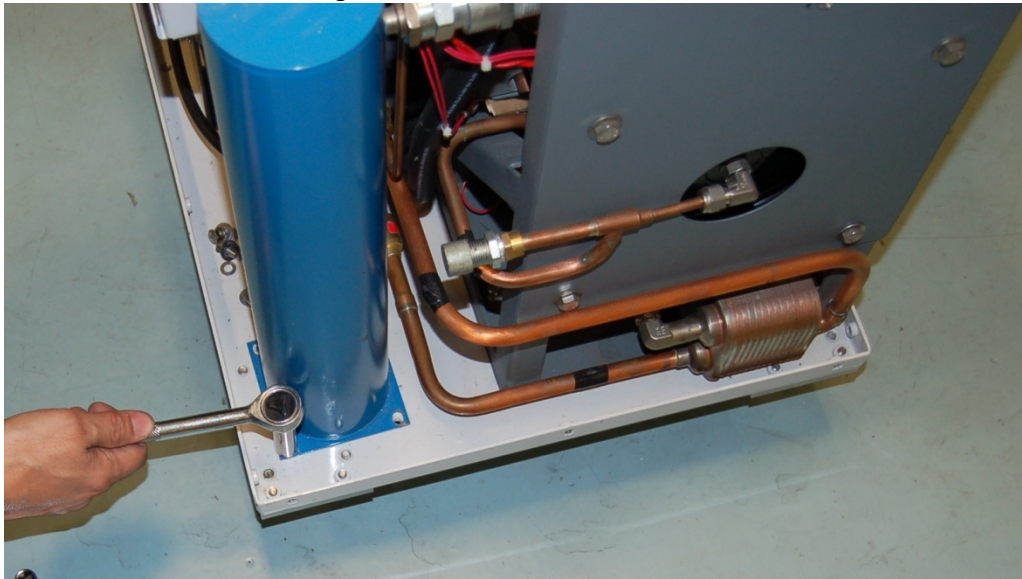

Figure 11 – Adsorber Removal



To detach the helium flex lines, perform the following:

1. Use two wrenches sized 1-1/8" and 1-3/16" to avoid loosening the body of the coupling from its adapter during removal (if optional installation kit purchased, utilize the two wrenches from the kit).
2. Hold 1-1-8" wrench tight on the coupling half attached to the adsorber.
3. Use the 1-3/16" wrench to loosen and disconnect the coupling to the helium supply and OMS line.



Caution: Detaching helium flex lines with the compressor load at low temperature (i.e. without proper warming-up) can result in loss of helium and/or pressure rise in the compressor unit beyond its designed maximum pressure level.

Note: Unscrew the two-self sealing coupling halves quickly to minimize minor gas leakage. See Figure 12 for an illustration of the self-sealing coupling

Figure 12 – Self Sealing Connector

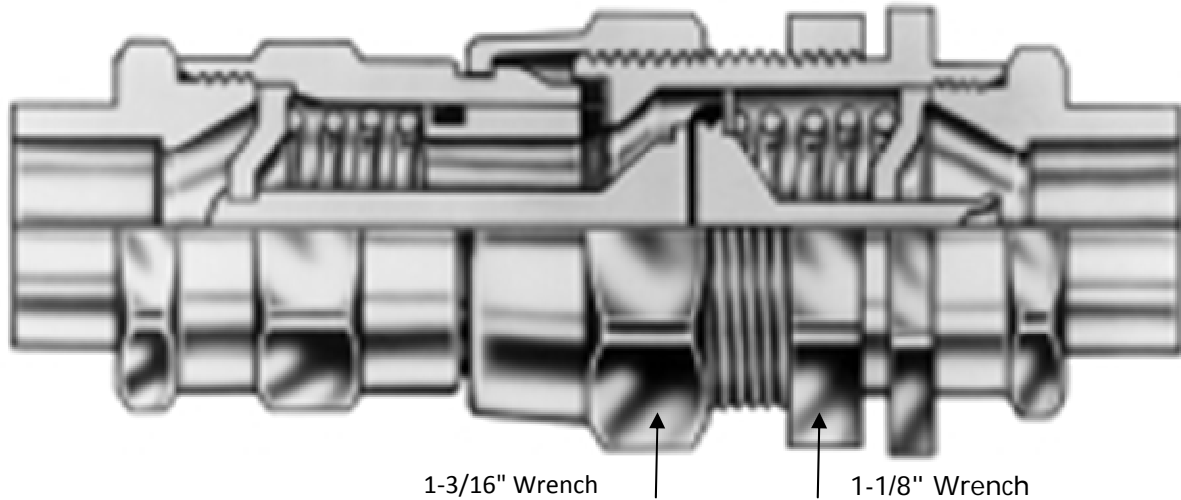

Note: Image from Aeroquip Catalog

8.3.2 Install Replacement Adsorber

To install the replacement adsorber:

1. Remove the dust caps from the self-sealing coupling halves at each end of the replacement adsorber.
2. Check the self-sealing connector flat rubber gasket to make sure that it is clean and properly positioned.
3. Place the adsorber back in the compressor using the clamp, bolt and washer set aside during the removal process described in Section 8.3.1.
4. Install the two-self sealing coupling halves quickly to minimize minor gas leakage.
5. Use the 1-1/8" and 1-3/16" wrenches, holding the 1-1/8" wrench tight on the coupling half attached to the adsorber. Use the 1-3/16" wrench to tighten the coupling to the helium supply/OMS line.
6. Make the initial turns by hand and then use the wrenches until the fittings bottom out. **This is critical, improper or loose connections will affect compressor function.**
 - a. Effective connections can be validated by confirming the leak rate is less than 1×10^{-5} mBar -l/sec
7. Make sure the supply pressure is in accordance to the pressures found in **Table 4-4**. If the pressure is either too high or too low, follow the instructions in Section 5.2.4.2 to add helium gas to the compressor.
8. Write the installation date and number of running hours (if known) on the decal provided with the replacement adsorber.
9. Re-install the cover panel that was removed in Section 8.3.1.
10. Restart the compressor.
11. Re-set the maintenance timer, see Section 6.3.6 (if applicable).

8.4 Unscheduled Corrective Maintenance

The following corrective maintenance activities may be necessary should the helium gas circuit of Model M700 compressor becomes contaminated.



8.4.1 Removing Helium Contamination

Helium contamination is usually indicated by irregular, noisy, or intermittent operation (ratcheting), and sometimes the seizure of the coldhead or cryopump drive mechanism. This is caused by the accumulation of frozen contaminants within the compressor load and resulting in interference. The source of the helium contamination is due to either:

- Inadvertent introduction of ambient air into the system
 - Use of helium with purity of less than 99.999% (He 5.0 UH), such as helium gas used for leak detection and welding.
- Minor contamination can usually be removed by running the coldhead or cryopump for several hours to trap the contaminants in the coldhead/cryopump, then shutting down the compressor and immediately removing the helium lines at the compressor. Then allow for the coldhead/cryopump to warm thoroughly and perform the helium cleanup procedures as outlined in the coldhead/cryopump manual.
- Stubborn contamination involving water vapor requires decontamination of the compressor. One effective method involves supplying clean helium to the return side of the compressor at appropriate pressures while venting a small amount of gas from the supply side while the compressor is running. This is referred to as a “running purge.” Contact Trillium US Inc. if such a procedure is needed.

The steps to remove compressor decontamination: (with the compressor running)

1. Set the helium regulator to whatever the compressor return pressure gauge reads (i.e. 50 PSIG)
2. Attach the helium charge line to the running purge fill fitting
3. Attach the running purge fill fitting to the return Aeroquip
4. Loosely attach the running purge vent fitting to the supply Aeroquip
5. Slowly tighten the running purge vent tool until helium is venting from the vent tool
6. Open the regulator valve and watch the compressor pressure gauge. The pressure should be stable at the pressure set in step 1. The adjustment of the regulator or the amount of helium venting from the compressor may need to be performed in order to maintain stability.
7. Once the pressure is stabilized, allow the running purge to continue for a minimum of 15 minutes.
8. After a minimum of 15 minutes, stop the running purge by first removing the running purge vent tool. Next, close the regulator valve and remove the helium charge line from the compressor.
9. Turn off the compressor.
10. Remove the running purge tools from the compressor.
11. Check the static pressure and readjust the pressure to the proper limits (see **Table 4-3**) in accordance with Section **5.2.4.2**.

8.5 Returning Equipment

Before returning any equipment, contact Trillium US Inc. to receive special instructions and to obtain a return authorization (RMA) number. See contact information in Section **2.2**.

Figure 13 – M700 Water Piping and Instrumentation Diagram

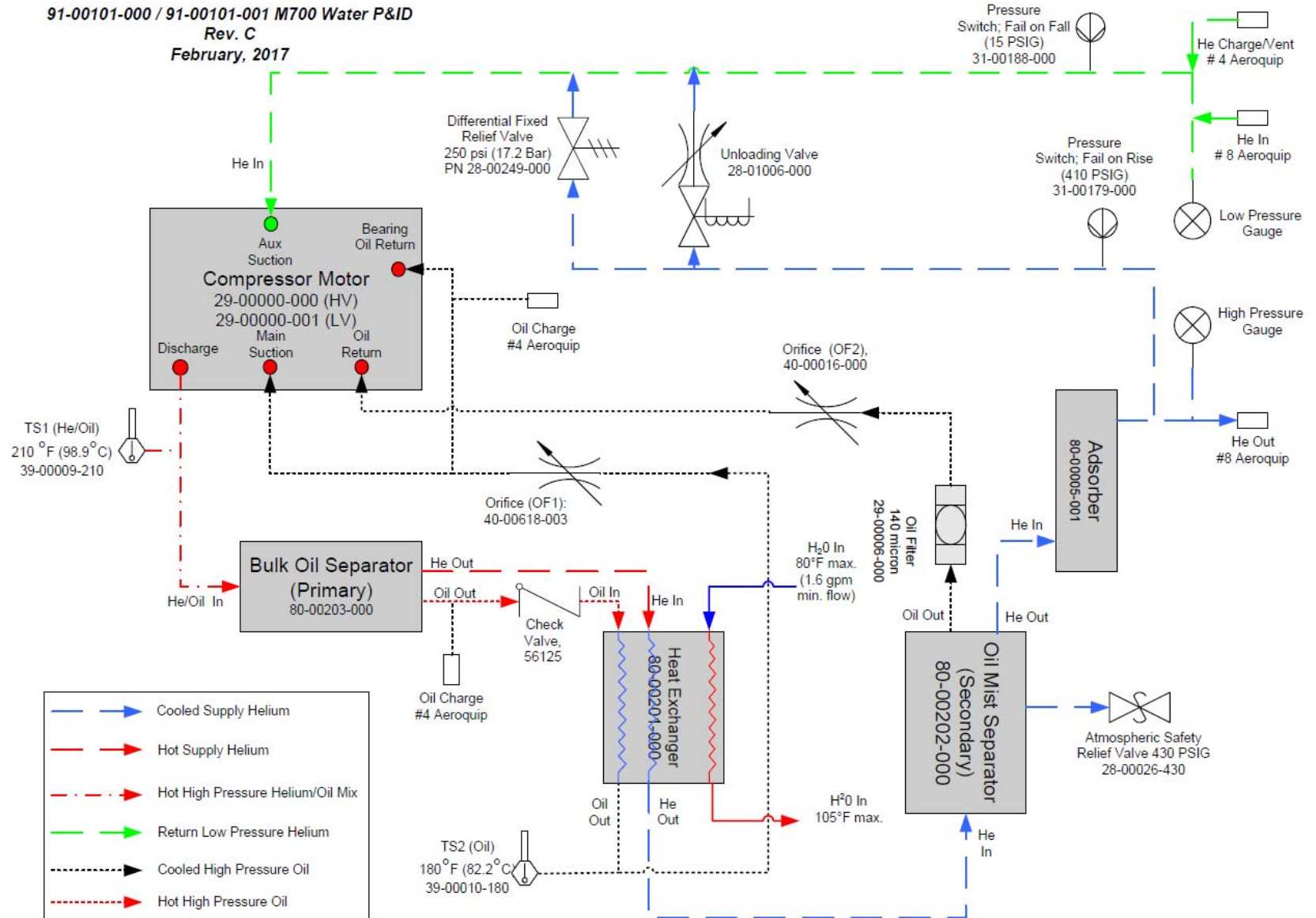
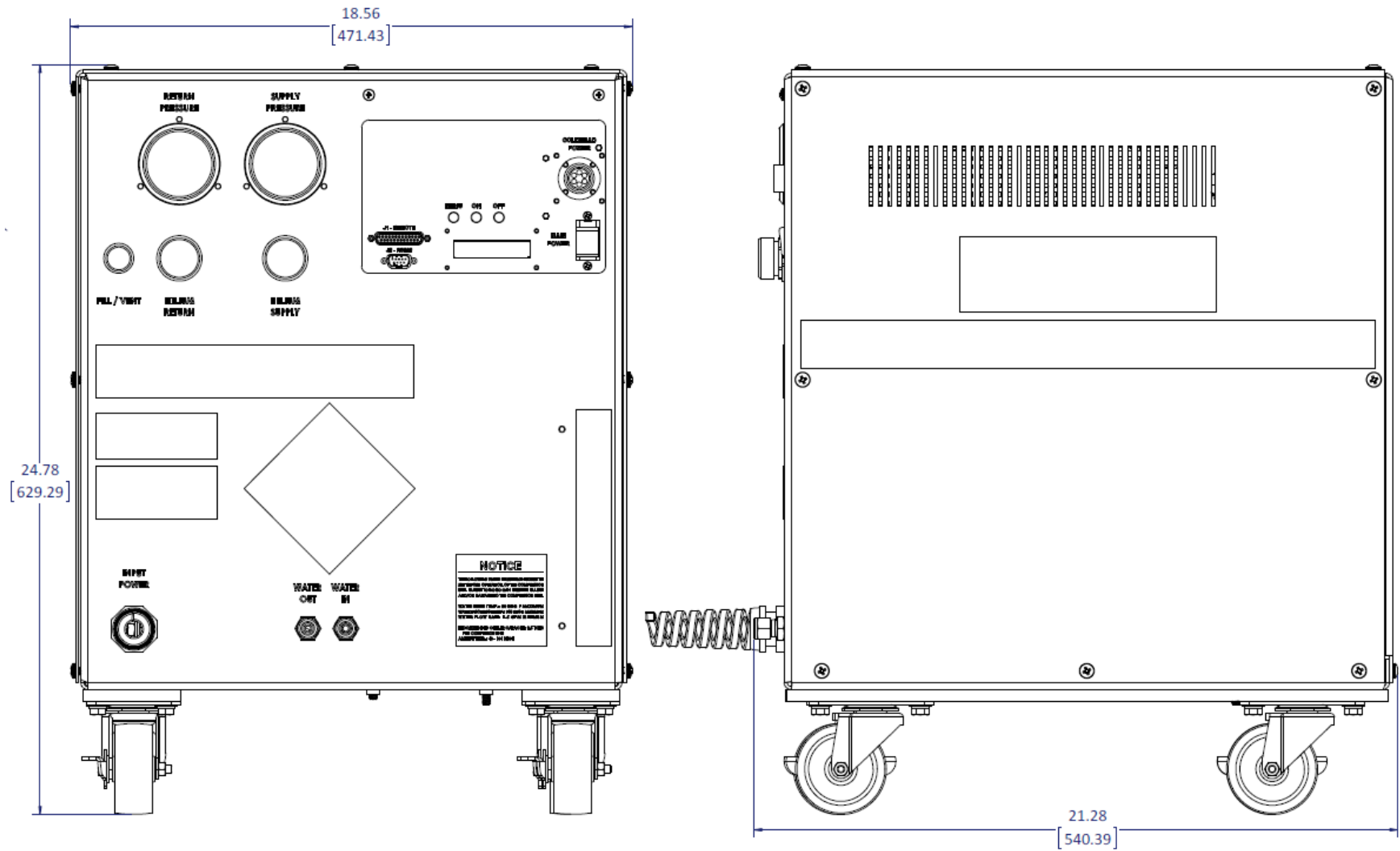

Figure 14 – M700 Water General Dimensions



OVERALL DIMENSIONS: in [mm]



Figure 15 – M700 Water Low Volt Standard Drive Schematic

Schematic; EBOX LV M700/M600/M400 W/LCD DISPLAY STD DRIVE
93-00100-009, Rev. A
Trilium US Inc. Proprietary & Confidential

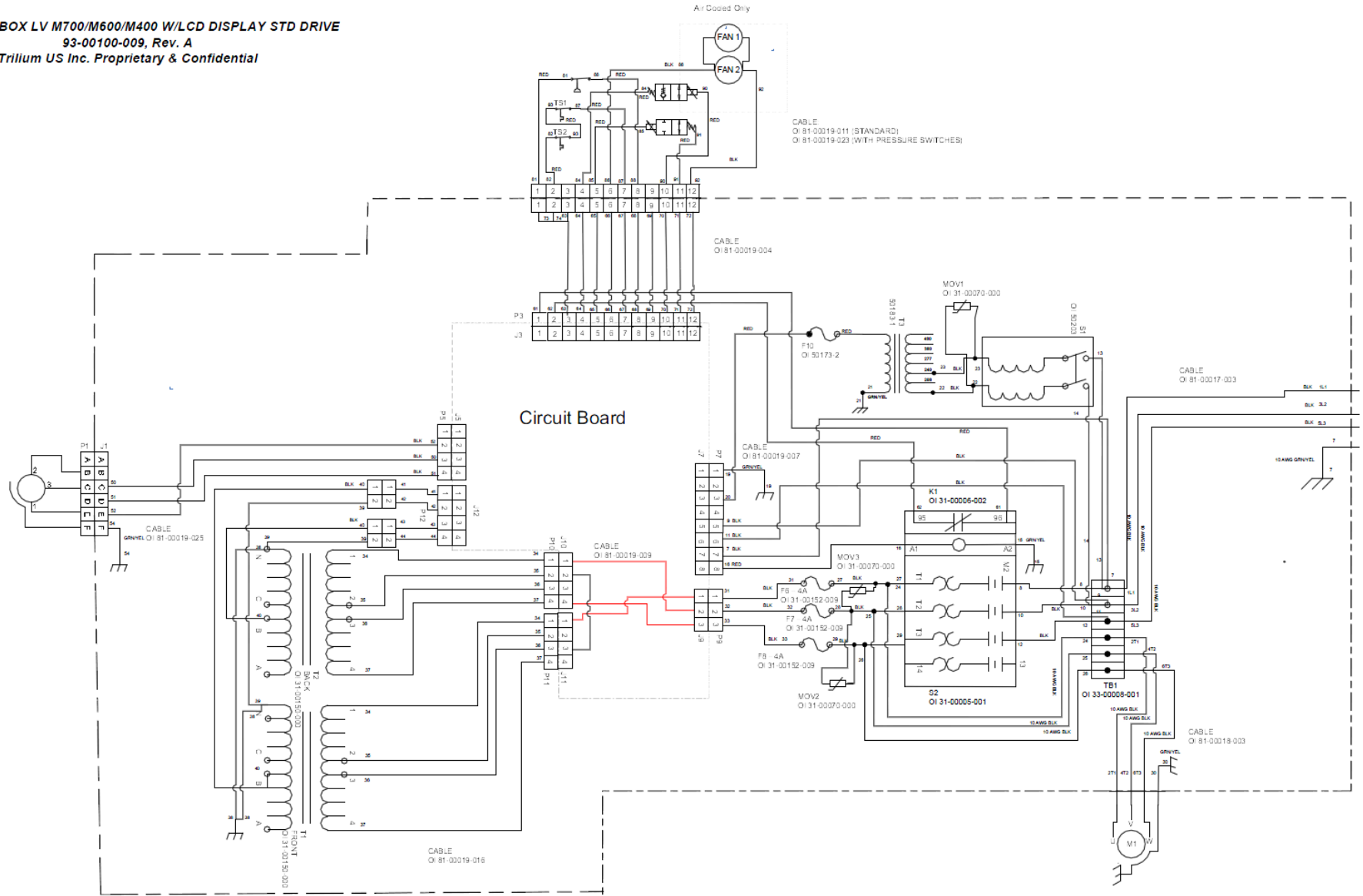

Figure 16 – M700 Water High Volt Standard Drive Schematic

SCHEMATIC; EBOX HV M700/M600/M400 W/LCD DISPLAY STD DRIVE
 93-00100-008, Rev. C
 Trillium US Inc. Proprietary & Confidential

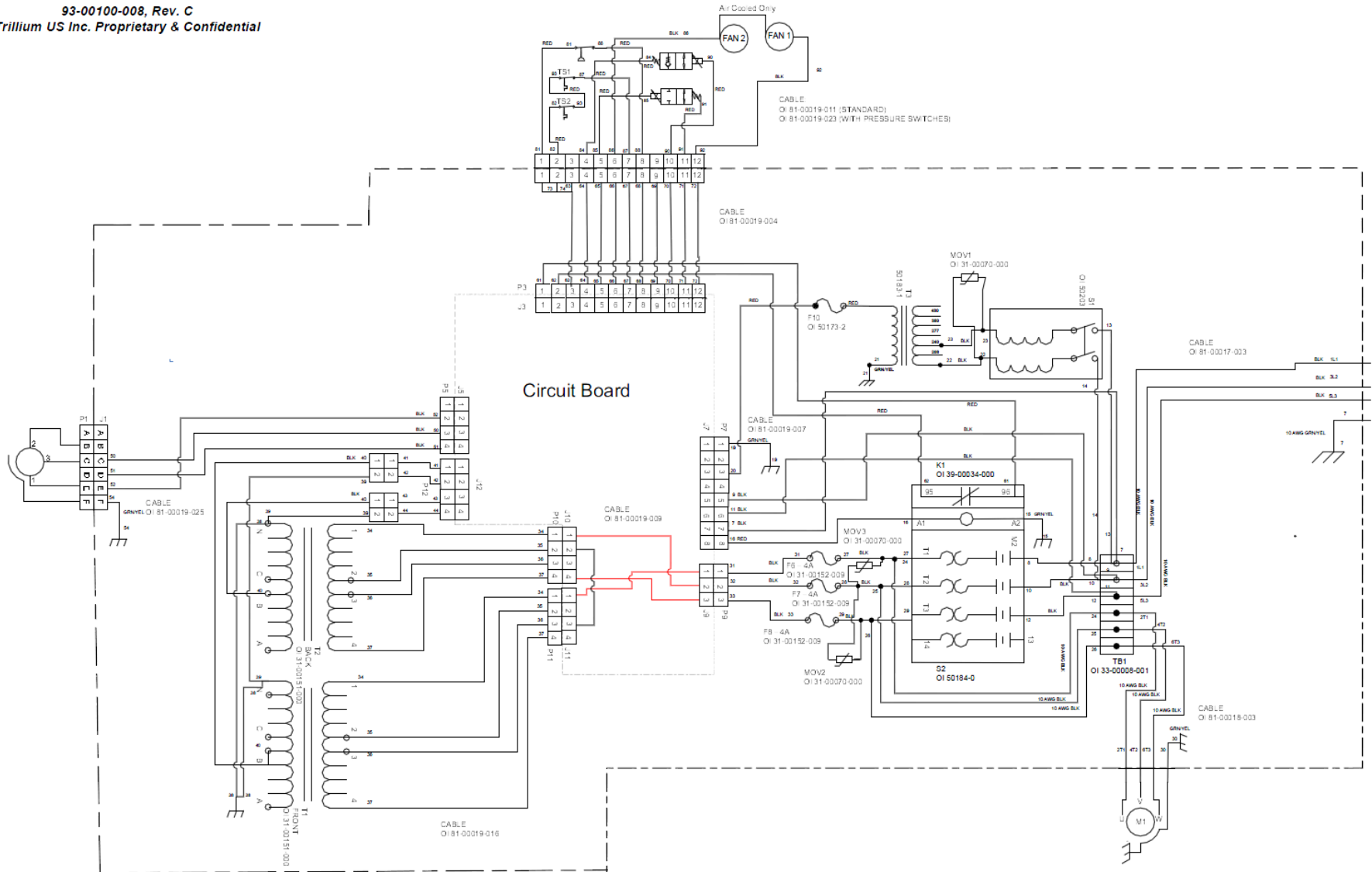

Figure 17 – M700 Water Low Volt Onboard Drive Schematic

SCHEMATIC; EBOX LV ONBOARD DRIVE M700/M600/M400 WITH CIRCUIT BOARD ASC WHITE
93-00100-010, Rev. C
Trillium US Inc. Proprietary & Confidential

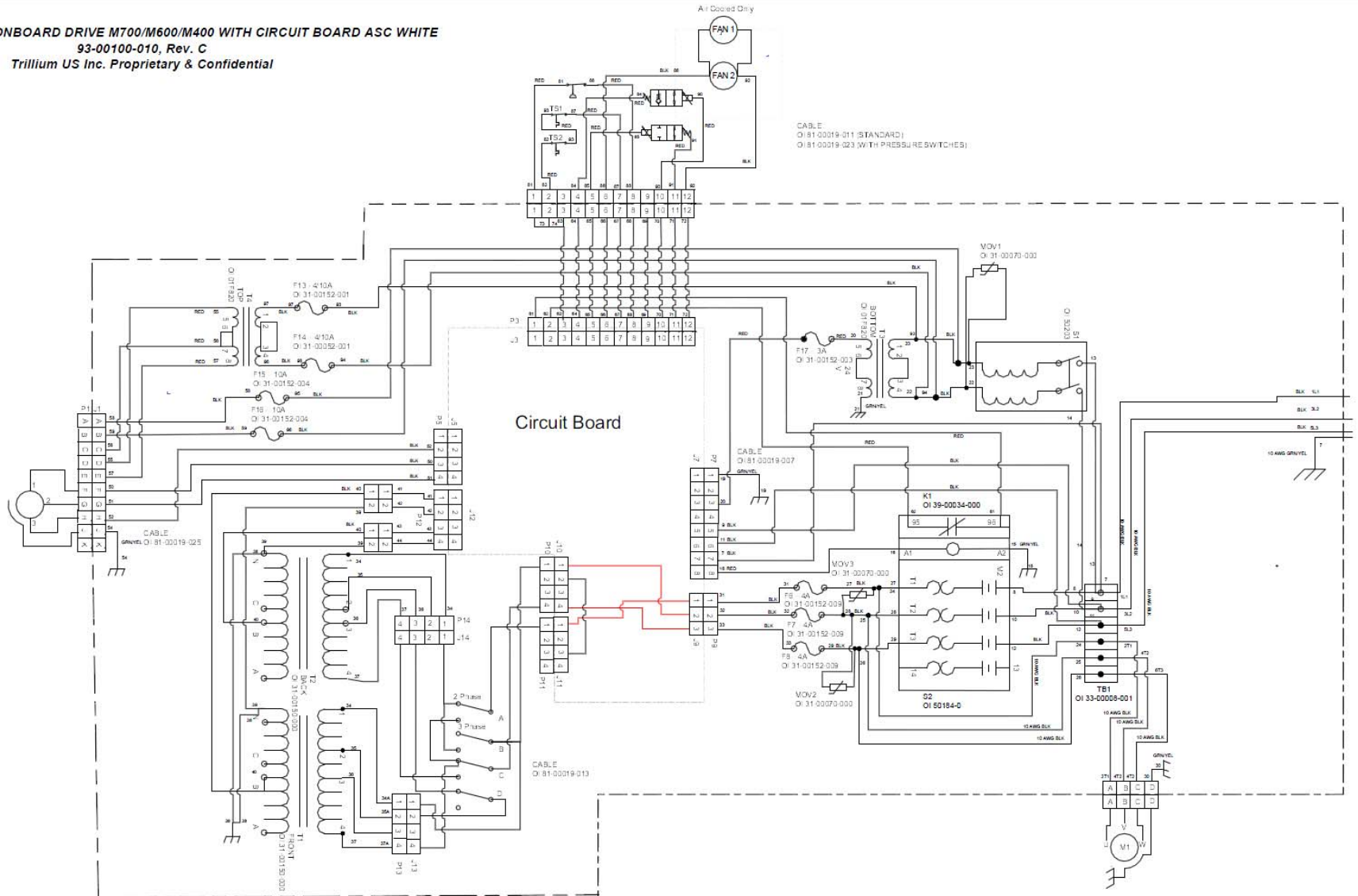

Figure 18 – M700 Water Low Volt Multi-Drive Schematic

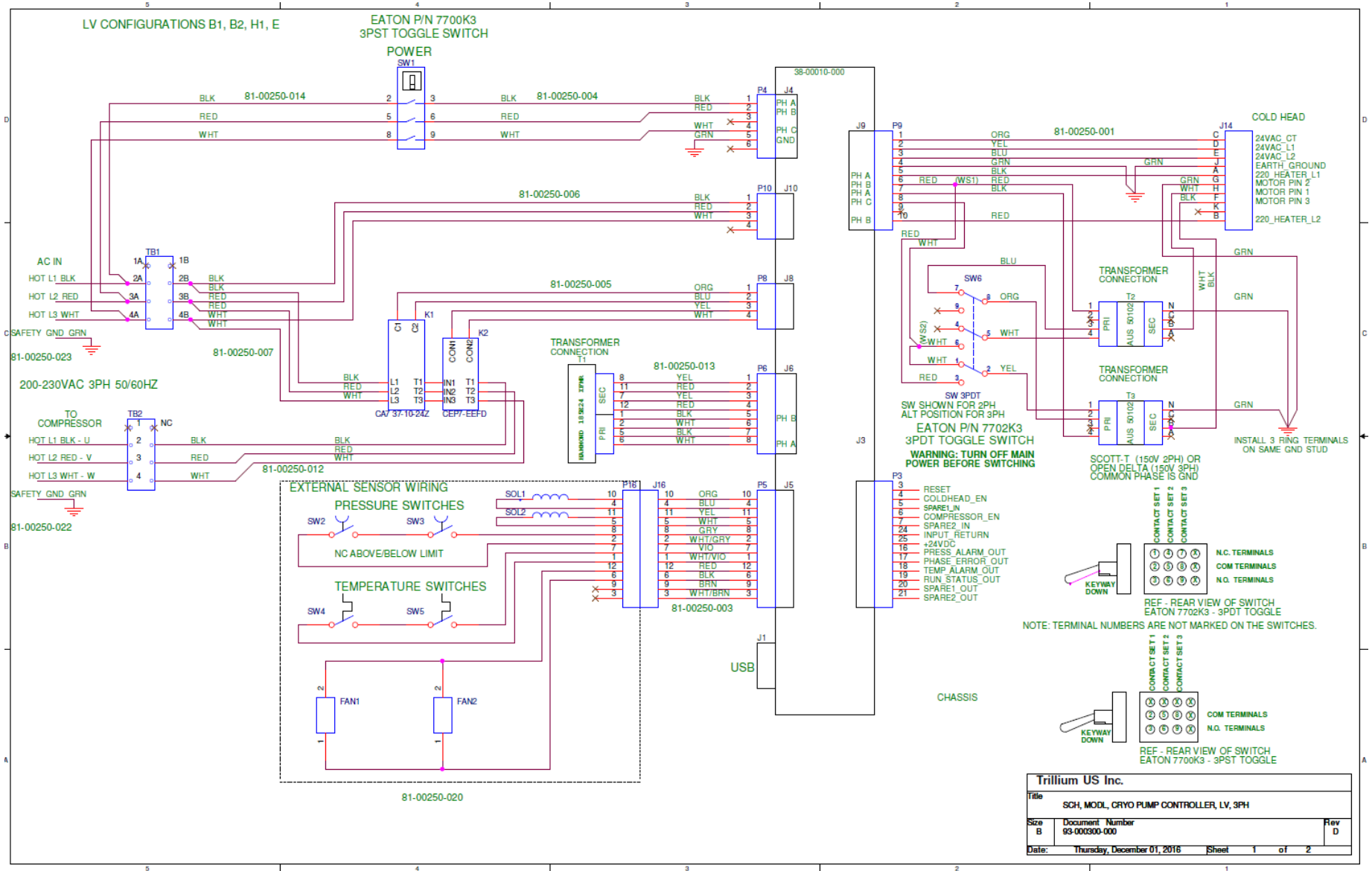

Figure 19 – M700 Water High Volt Multi-Drive Schematic

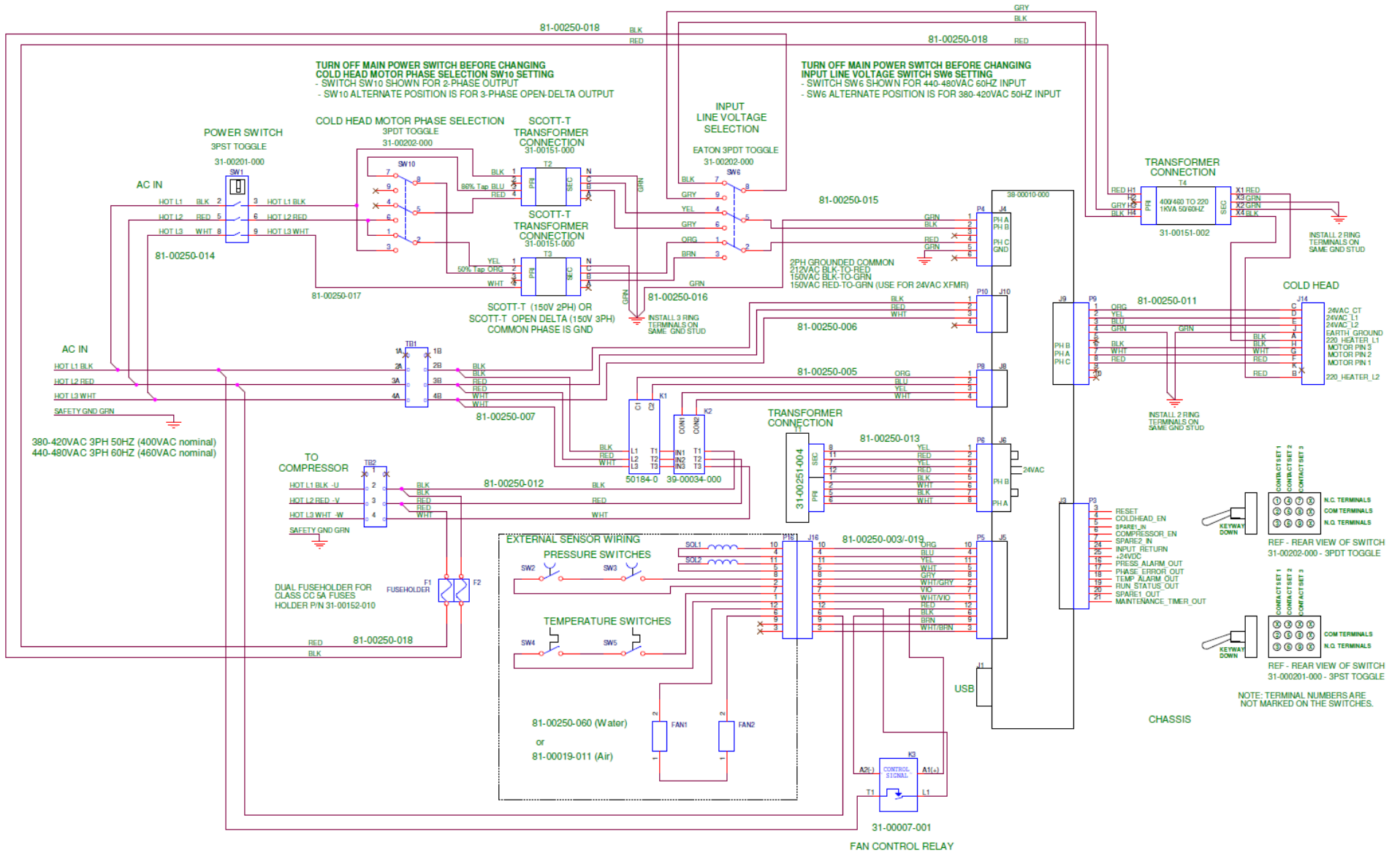

Figure 20 – M700 Fault Tree: Compressor will Not Start / Adsorber Replacement



Tuesday, December 06, 2016

M700 Compressor Fault Tree

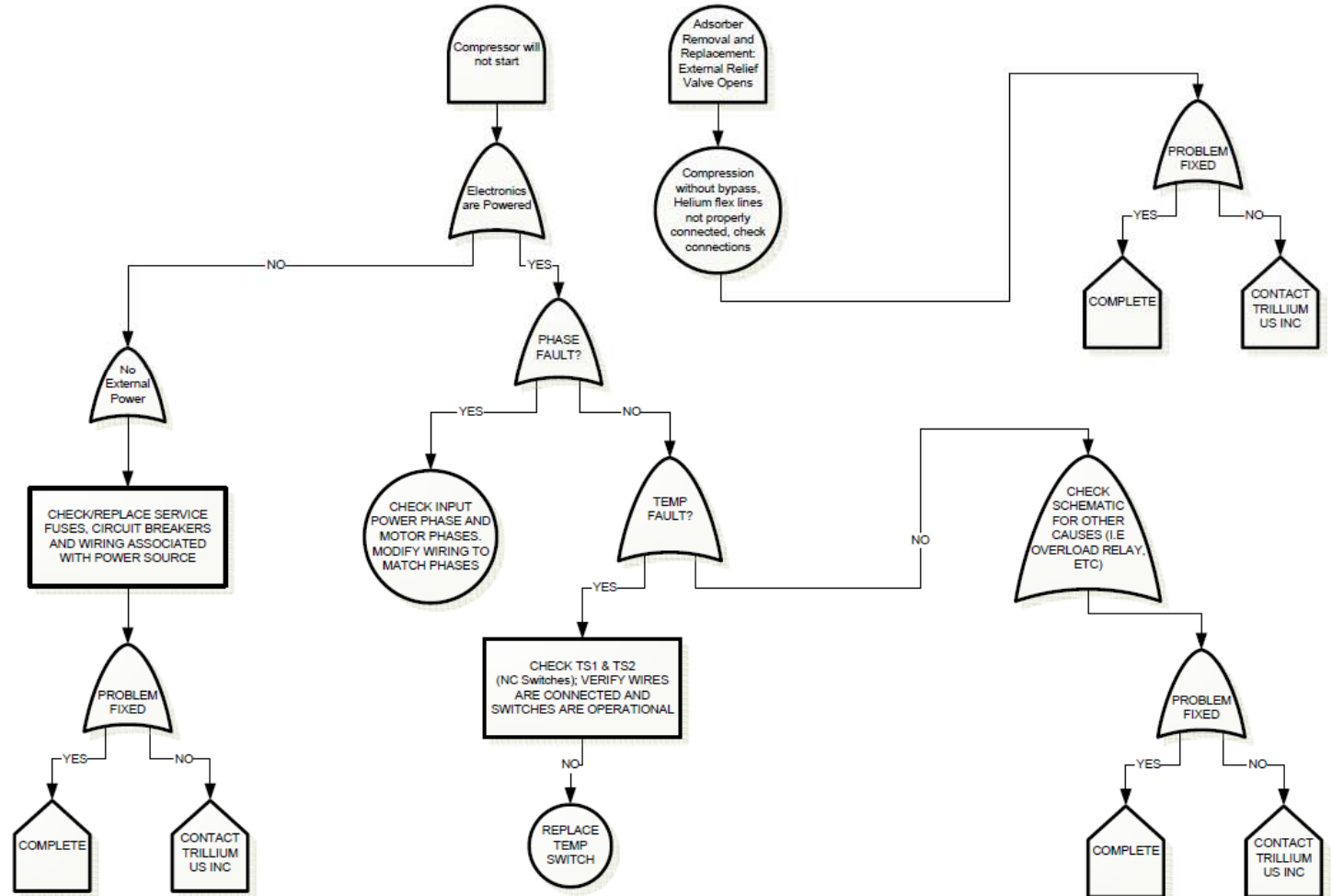

Figure 21 – M700 Fault Tree: Compressor Starts but Shuts Off



M700 Compressor Fault Tree

Tuesday, December 06, 2016

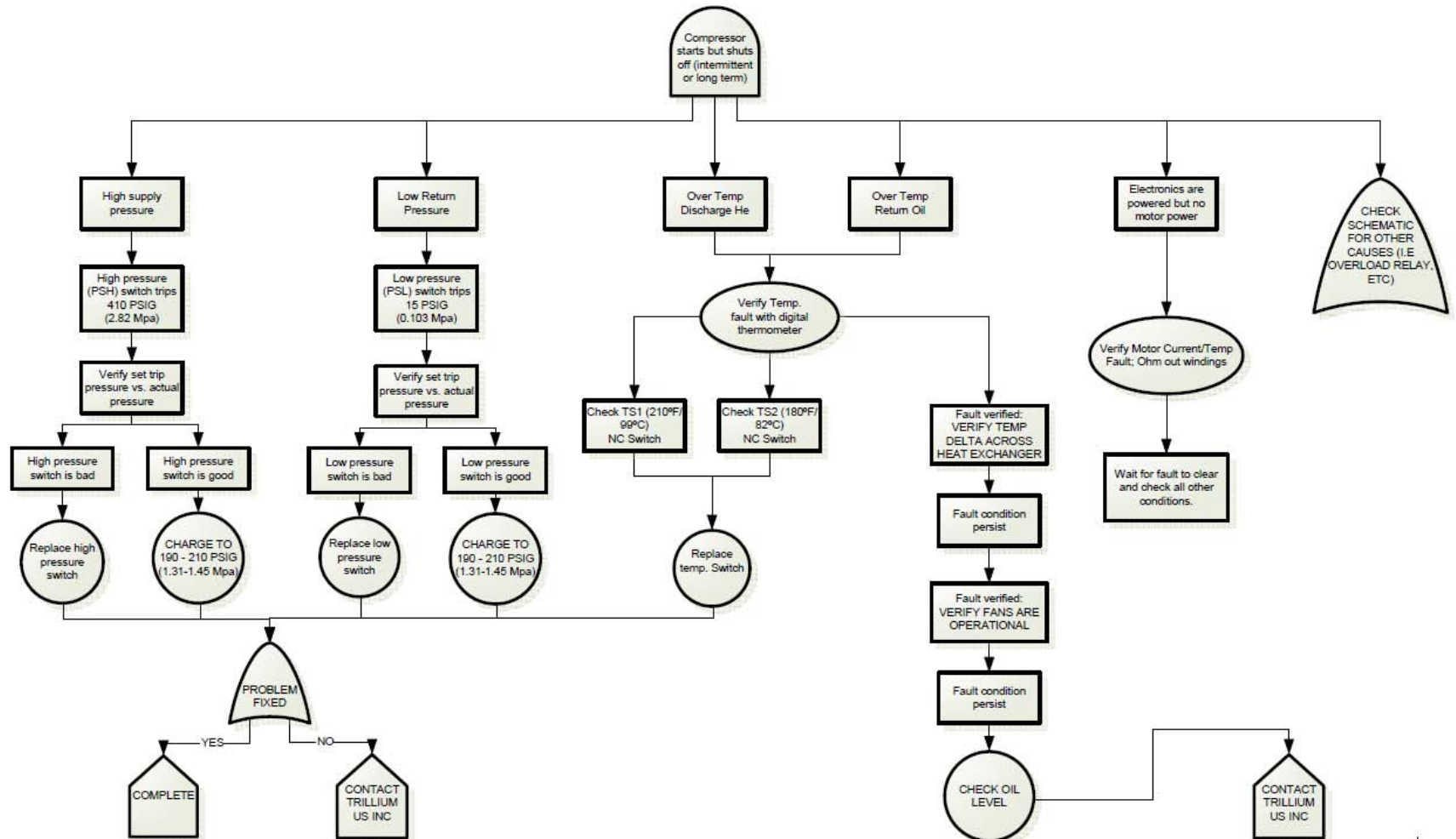
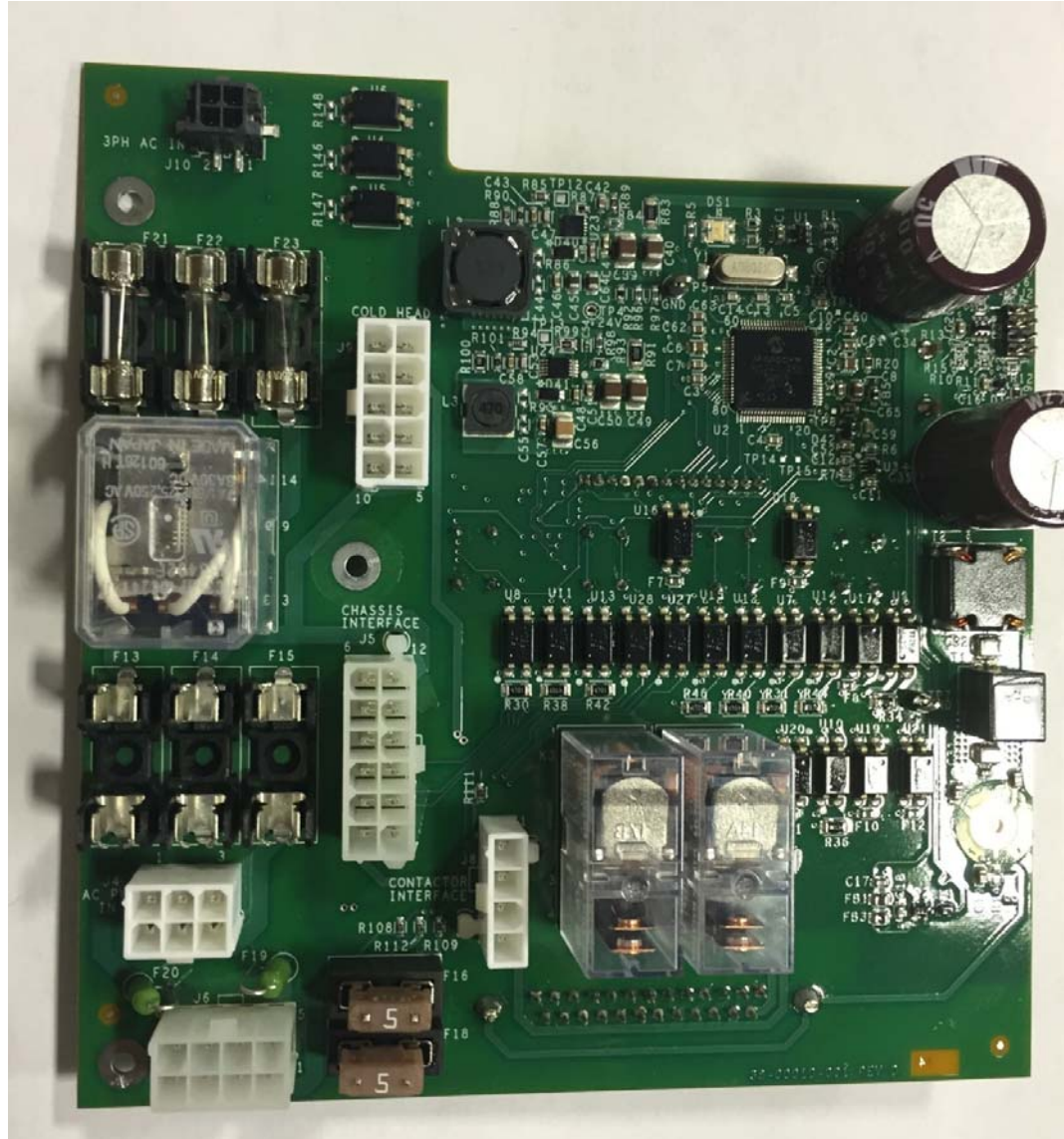

Figure 22 – M700 Fuse Locations for Electronics Boxes in Figure 2 and Figure 3



Figure 23 – M700 Fuse Locations for Electronics Boxes in Figure 4 and Figure 5



*F21, F22 and F23 are not present on all revisions of the PCBA



Figure 24 – 99-00074-000 Tool Kit Contents

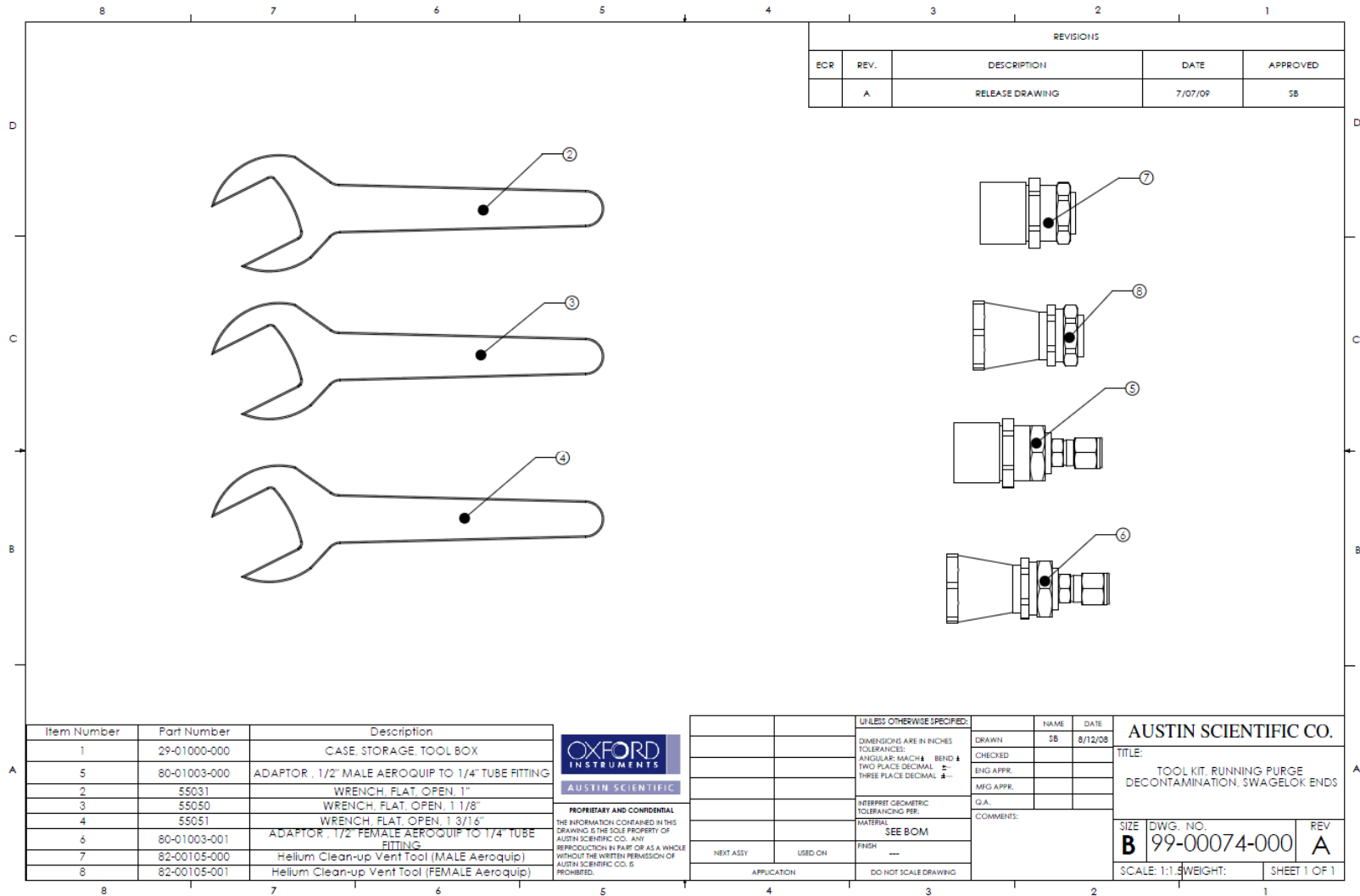

Figure 25 – 99-00074-001 Tool Kit Contents

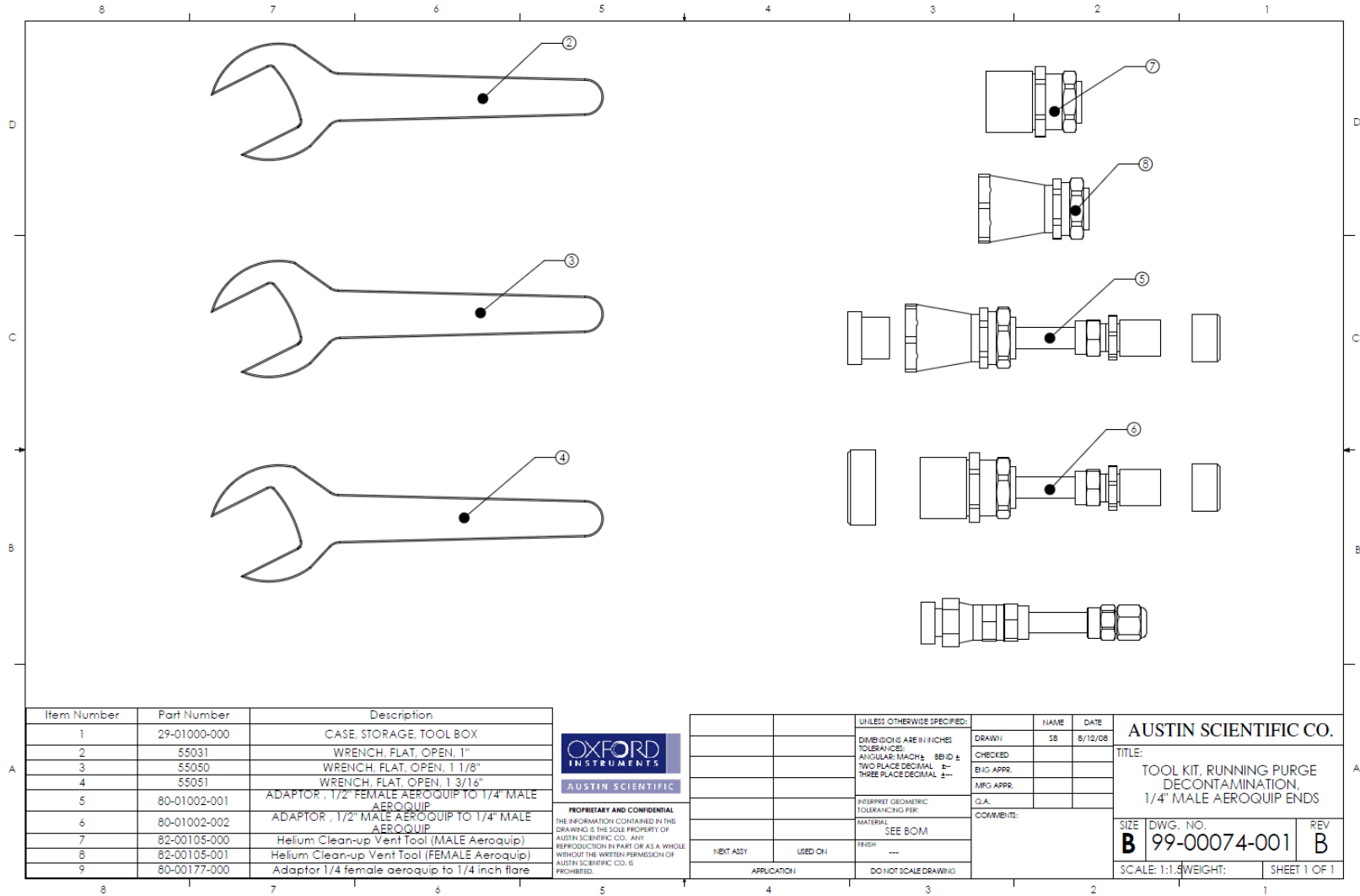
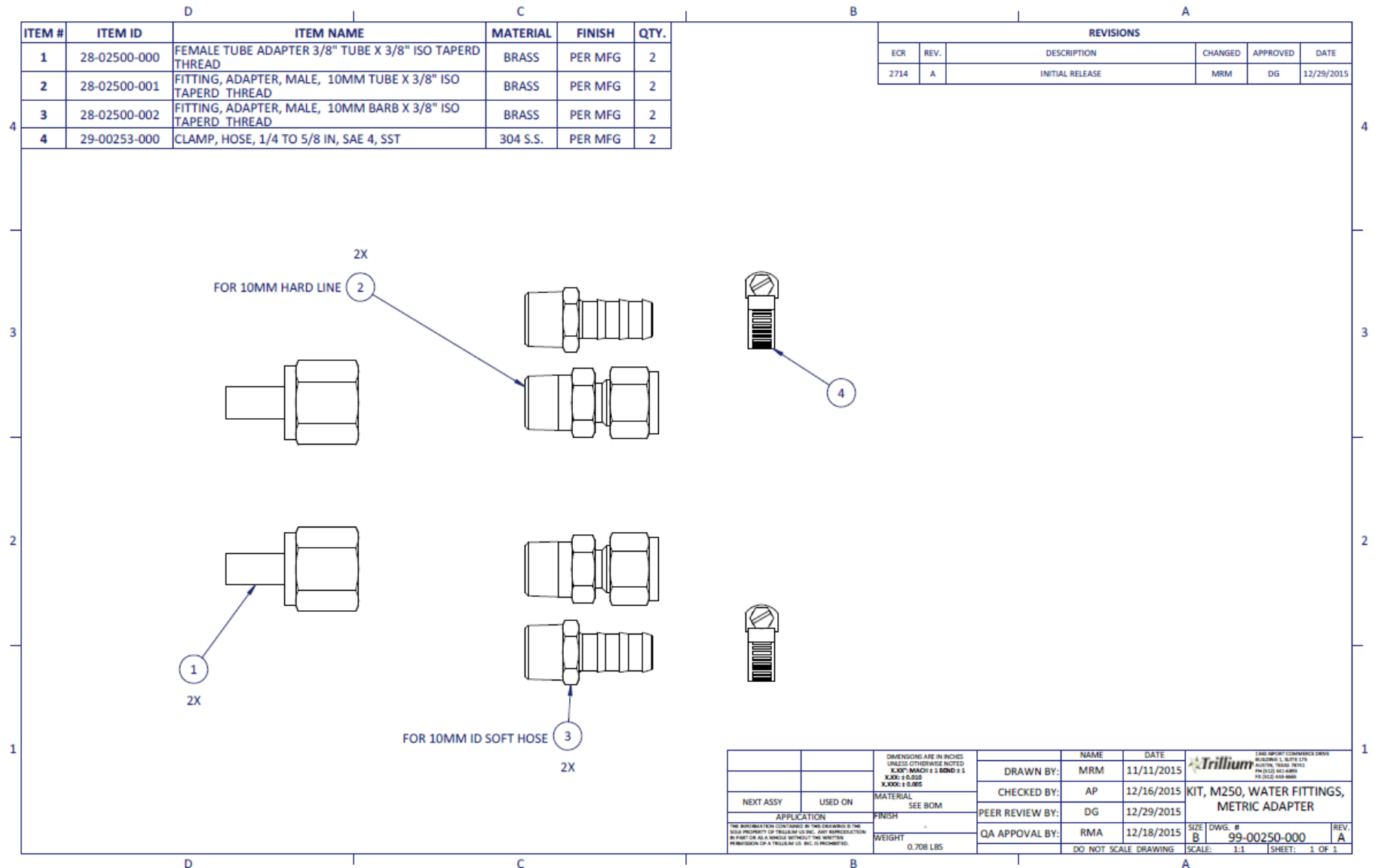

Figure 26 – 99-00250-000 Kit Contents



This Page Intentionally Left Blank

